



Programmable Terminal NA-series

Practices Guide MC Test Run IAG Library

NA5-15W□□□□
NA5-12W□□□□
NA5-9W□□□□
NA5-7W□□□□

Practices
Guide

■ Introduction

This guide provides reference information for the use of MC Test Run IAG library. It does not provide safety information.

Be sure to obtain the NA-series Programmable Terminal User's Manuals, read and understand the safety points and other information required for use, and test sufficiently before actually using the equipment.

Sysmac and SYSMAC are trademarks or registered trademarks of OMRON Corporation in Japan and other countries for OMRON factory automation products.

Other company names and product names in this document are the trademarks or registered trademarks of their respective companies.

Microsoft product screen shots are reprinted with permission from Microsoft Corporation.

Terms and Conditions Agreement

Warranty, Limitations of Liability

Warranties

- Exclusive Warranty

Omron's exclusive warranty is that the Products will be free from defects in materials and workmanship for a period of twelve months from the date of sale by Omron (or such other period expressed in writing by Omron). Omron disclaims all other warranties, express or implied.

- Limitations

OMRON MAKES NO WARRANTY OR REPRESENTATION, EXPRESS OR IMPLIED, ABOUT NON-INFRINGEMENT, MERCHANTABILITY OR FITNESS FOR A PARTICULAR PURPOSE OF THE PRODUCTS. BUYER ACKNOWLEDGES THAT IT ALONE HAS DETERMINED THAT THE PRODUCTS WILL SUITABLY MEET THE REQUIREMENTS OF THEIR INTENDED USE.

Omron further disclaims all warranties and responsibility of any type for claims or expenses based on infringement by the Products or otherwise of any intellectual property right.

- Buyer Remedy

Omron's sole obligation hereunder shall be, at Omron's election, to (i) replace (in the form originally shipped with Buyer responsible for labor charges for removal or replacement thereof) the non-complying Product, (ii) repair the non-complying Product, or (iii) repay or credit Buyer an amount equal to the purchase price of the non-complying Product; provided that in no event shall Omron be responsible for warranty, repair, indemnity or any other claims or expenses regarding the Products unless Omron's analysis confirms that the Products were properly handled, stored, installed and maintained and not subject to contamination, abuse, misuse or inappropriate modification. Return of any Products by Buyer must be approved in writing by Omron before shipment. Omron Companies shall not be liable for the suitability or unsuitability or the results from the use of Products in combination with any electrical or electronic components, circuits, system assemblies or any other materials or substances or environments. Any advice, recommendations or information given orally or in writing, are not to be construed as an amendment or addition to the above warranty.

See <http://www.omron.com/global/> or contact your Omron representative for published information.

Limitation on Liability; Etc

OMRON COMPANIES SHALL NOT BE LIABLE FOR SPECIAL, INDIRECT, INCIDENTAL, OR CONSEQUENTIAL DAMAGES, LOSS OF PROFITS OR PRODUCTION OR COMMERCIAL LOSS IN ANY WAY CONNECTED WITH THE PRODUCTS, WHETHER SUCH CLAIM IS BASED IN CONTRACT, WARRANTY, NEGLIGENCE OR STRICT LIABILITY.

Further, in no event shall liability of Omron Companies exceed the individual price of the Product on which liability is asserted.

Application Considerations

Suitability of Use

Omron Companies shall not be responsible for conformity with any standards, codes or regulations which apply to the combination of the Product in the Buyer's application or use of the Product. At Buyer's request, Omron will provide applicable third party certification documents identifying ratings and limitations of use which apply to the Product. This information by itself is not sufficient for a complete determination of the suitability of the Product in combination with the end product, machine, system, or other application or use. Buyer shall be solely responsible for determining appropriateness of the particular Product with respect to Buyer's application, product or system. Buyer shall take application responsibility in all cases.

NEVER USE THE PRODUCT FOR AN APPLICATION INVOLVING SERIOUS RISK TO LIFE OR PROPERTY WITHOUT ENSURING THAT THE SYSTEM AS A WHOLE HAS BEEN DESIGNED TO ADDRESS THE RISKS, AND THAT THE OMRON PRODUCT(S) IS PROPERLY RATED AND INSTALLED FOR THE INTENDED USE WITHIN THE OVERALL EQUIPMENT OR SYSTEM.

Programmable Products

Omron Companies shall not be responsible for the user's programming of a programmable Product, or any consequence thereof.

Disclaimers

Performance Data

Data presented in Omron Company websites, catalogs and other materials is provided as a guide for the user in determining suitability and does not constitute a warranty. It may represent the result of Omron's test conditions, and the user must correlate it to actual application requirements. Actual performance is subject to the Omron's Warranty and Limitations of Liability.

Change in Specifications

Product specifications and accessories may be changed at any time based on improvements and other reasons. It is our practice to change part numbers when published ratings or features are changed, or when significant construction changes are made. However, some specifications of the Product may be changed without any notice. When in doubt, special part numbers may be assigned to fix or establish key specifications for your application. Please consult with your Omron's representative at any time to confirm actual specifications of purchased Product.

Errors and Omissions

Information presented by Omron Companies has been checked and is believed to be accurate; however, no responsibility is assumed for clerical, typographical or proofreading errors or omissions.

Contents

- Terms and Conditions Agreement..... 3**

- Warranty, Limitations of Liability 3
- Application Considerations 4
- Disclaimers 4

- Contents 5**

- 1 Related Manuals 7**

- 2 Precautions 8**

- 3 Introduction 9**

- 3-1 Applicable Model 10
- 3-2 Object Configuration..... 10
- 3-3 Outline of System Configuration 12

- 4 Use Cases..... 13**

- 4-1 Axis Test Run Screen..... 13
- 4-2 Axis Test Run Pop-up Page..... 14

- 5 Details of IAG Specifications..... 15**

- 5-1 Axis Status Monitor IAG 15
- 5-2 Jog Feed IAG 19
- 5-3 Absolute Positioning IAG 23
- 5-4 Relative Positioning IAG 27
- 5-5 Homing IAG..... 31

- 6 Details of FB Specifications 35**

- 6-1 Axis Information Acquire FB..... 35
- 6-2 Manual Operation FB 37

7 Details of Variable Specifications 39

7-1 Structures Registered in FB Library of NJ.....39
7-2 Structures Registered in IAG Object of NA40

8 Install Procedure..... 41

8-1 Registering NJ Variables42
8-2 Importing FB Library File44
8-3 Adding FB to NJ Program45
8-4 Adding Axis Start Variables.....47
8-5 Registering and Mapping NA Variables50
8-6 Importing IAG File.....52
8-7 Placing IAG Object on NA Screen.....53
8-8 Adding Subroutine/ Event and Action to Page.....55

Revision History 62

1 Related Manuals

The following manuals are related to this guide.

Cat. No.	Model	Manual name
V117	NA5-15W□□□□ NA5-12W□□□□ NA5-9W□□□□ NA5-7W□□□□	NA-series Programmable Terminal Hardware User's Manual
V118	NA5-15W□□□□ NA5-12W□□□□ NA5-9W□□□□ NA5-7W□□□□	NA-series Programmable Terminal Software User's Manual
V119	NA5-15W□□□□ NA5-12W□□□□ NA5-9W□□□□ NA5-7W□□□□	NA-series Programmable Terminal Device Connection User's Manual
V120	NA5-15W□□□□ NA5-12W□□□□ NA5-9W□□□□ NA5-7W□□□□	NA-series Programmable Terminal Startup Guide
W505	NX701-1□□□ NJ501-1□□□ NJ301-1□□□ NJ101-10□□	NJ/NX-series CPU Unit Built-in EtherCAT® Port User's Manual
W507	NX701-1□□□ NJ501-1□□□ NJ301-1□□□ NJ101-10□□	NJ/NX-series CPU Unit Motion Control User's Manual
I576	R88M-K□ (AC Servomotors) R88D-KN□-ECT (Servo Drives)	AC Servomotors/Servo Drives G5-series (Built-in EtherCAT® Communications) User's Manual
I586	R88M-1L□/-1M□ (AC Servomotors) R88D-1SN□-ECT (AC Servo Drives)	AC Servomotors/Servo Drives 1S-series (Built-in EtherCAT® Communications) User's Manual
W504	SYSMAC-SE2□□□	Sysmac Studio Version 1 Operation Manual

2 Precautions

- (1) When building an actual system, check the specifications of the component devices of the system, use within the ratings and specified performance, and implement safety measures such as safety circuits to minimize the possibility of an accident.
- (2) For safe use of the system, obtain the manuals of the component devices of the system and check the information in each manual, including safety precautions, precautions for safe use.
- (3) It is the responsibility of the customer to check all laws, regulations, and standards that the system must comply with.
- (4) All rights reserved. No part of this publication may be reproduced, stored in a retrieval system, or transmitted, in any form, or by any means, mechanical, electronic, photocopying, recording, or otherwise, without the prior written permission of OMRON.
- (5) The information in this guide is current as of June 2016.
No patent liability is assumed with respect to the use of the information contained herein. Moreover, because OMRON is constantly striving to improve its high-quality products, the information contained in this guide is subject to change without notice.
- (6) The operation of each IAG has tested using the device configuration indicated in this guide. However, the operation of screens after incorporating the IAG is not guaranteed.

Special information in this document is classified as follows:



Precautions for Safe Use

Indicates precautions on what to do and what not to do to ensure safe usage of the product.



Precautions for Correct Use

Indicates precautions on what to do and what not to do to ensure proper operation and performance.



Additional Information

Additional information to read as required.
This information is provided to increase understanding or make operation easier.

Copyrights and Trademarks

Screenshots are used in accordance with Microsoft Corporation guidelines.
Windows is a registered trademark of Microsoft Corporation in the USA and other countries.
EtherCAT® is registered trademark and patented technology, licensed by Beckhoff Automation GmbH, Germany.
Company names and product names in this document are the trademarks or registered trademarks of their respective companies.

3 Introduction

NJ user programs and HMI displays are modularized as function blocks (FB) and IAGs that are required to implement the MC Test Run of the Sysmac Studio on the HMI.

Combining the FB and IAG allows you to implement the following displays faster and easier.

- Test Run screen for motion axis
- Pop-up page for axis manual operation and sensor adjustment

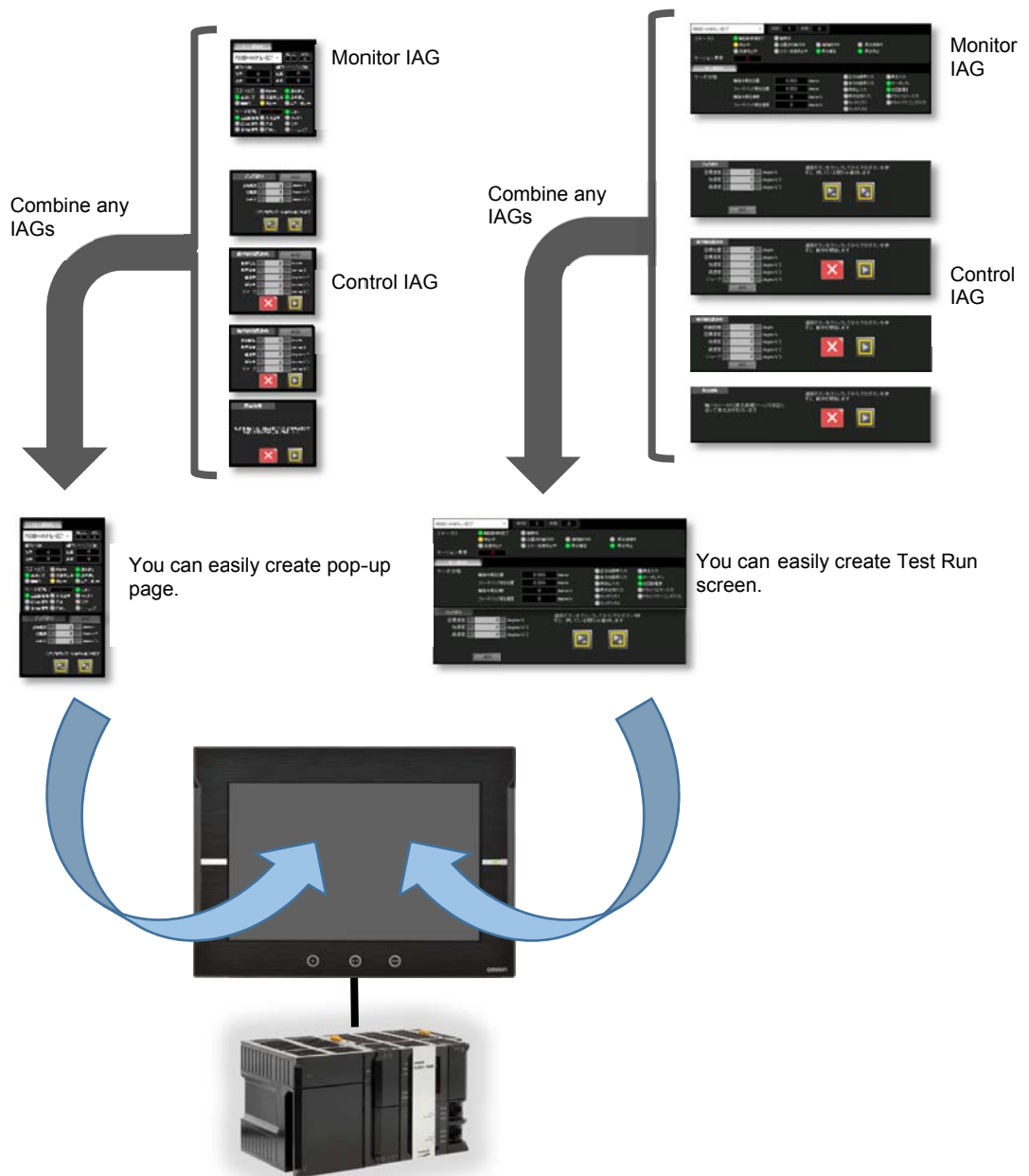

3-1 Applicable Model

Item	Name	Model	Version
Automation software	Sysmac Studio	SYSMAC-SE□□□□	V1.14 or later *1)
Device	Programmable Terminal	NA5-15W□□□□ NA5-12W□□□□ NA5-9W□□□□ NA5-7W□□□□	V1.03 or later
	CPU Unit	NJ501-□□□□ NJ301-□□□□ NJ101-10□□	V1.11 or later
	AC Servo Drives G5-series (Built-in EtherCAT® Communications)	R88D-KN□-ECT	-
	AC Servo Drives 1S-series (Built-in EtherCAT® Communications)	R88D-1SN□-ECT	-

*1) Sysmac Studio V1.16 or later can be used for AC Servo Drives 1S-series.



Additional Information

Restrictions on the use of each product above may be described in other manuals. Refer to Section 1 *Related Manuals* (P7).

3-2 Object Configuration

The Test Run IAG and FB libraries consist of the following objects;

- IAG object : 15 objects (5 types for pop-up page, 7/ 9 inch full-screen, and 12/ 15 inch full-screen, respectively)
- Function Block : 2 FBs

Type	Description	Detail
IAG library file (for Popup page) File name: DeviceWindowIAG_114A_E_MCTestRun_Popup.iag		IAG library files for pop-up and small-sized screens.
IAG	Axis status monitor_(Pop-up)	Displays the Servo ON/OFF and its status.
IAG	Jog feed_(Pop-up)	Sets the parameter for Jog feed and performs the operation.
IAG	Absolute positioning_(Pop-up)	Sets the parameter for absolute positioning and performs the operation.
IAG	Relative positioning_(Pop-up)	Sets the parameter for relative positioning and performs the operation.
IAG	Homing_(Pop-up)	Performs the homing.
IAG library file (for 7/ 9 inches) File name: DeviceWindowIAG_114A_E_MCTestRun_9inch.iag		IAG library files for 7/ 9 inch full-screen.
IAG	Axis status monitor_(Full-screen)	Displays the Servo ON/OFF and its status.
IAG	Jog feed_(Full-screen)	Sets the parameter for Jog feed and performs the operation.
IAG	Absolute positioning_(Full-screen)	Sets the parameter for absolute positioning and performs the operation.
IAG	Relative positioning_(Full-screen)	Sets the parameter for relative positioning and performs the operation.

IAG	Homing_(Full-screen)	Performs the homing.
IAG library file (for 12/ 15 inches) File name: DeviceWindowIAG_114A_E_MCTest Run_12inch.iag		IAG library files for 12/ 15 inch full-screen.
IAG	Axis status monitor_(Full-screen)	Displays the Servo ON/OFF and its status.
IAG	Jog feed_(Full-screen)	Sets the parameter for Jog feed and performs the operation.
IAG	Absolute positioning_(Full-screen)	Sets the parameter for absolute positioning and performs the operation.
IAG	Relative positioning_(Full-screen)	Sets the parameter for relative positioning and performs the operation.
IAG	Homing_(Full-screen)	Performs the homing.
Axis Information Acquire FB File name: IAGCont_DeviceWindow_ReadDeviceName_V1_0.sir		FB library file that acquires the axis information.
Function Block	Acquires axis information.	FB that acquires the axis information with SDO.
Manual Operation FB File name: IAGCont_DeviceWindow_MCTest Run_V1_0.sir		FB library file that performs manual operation.
Function Block	Performs manual operation.	FB that performs manual operation.

We also provide the following Excel file that simplifies a declaration of NJ variables.

- Excel for variable declaration: One file

Type	File name	Detail
Excel for variable declaration	MCTest RunIAG_Variables.xlsx	This is a list of NJ variables to be registered to the project using the IAG libraries.

3-3 Outline of System Configuration

Information between the IAGs and FBs are shared via the 3 mapping variables.
 Information between the FBs and Servo are shared via the axis variables and SDO communications.

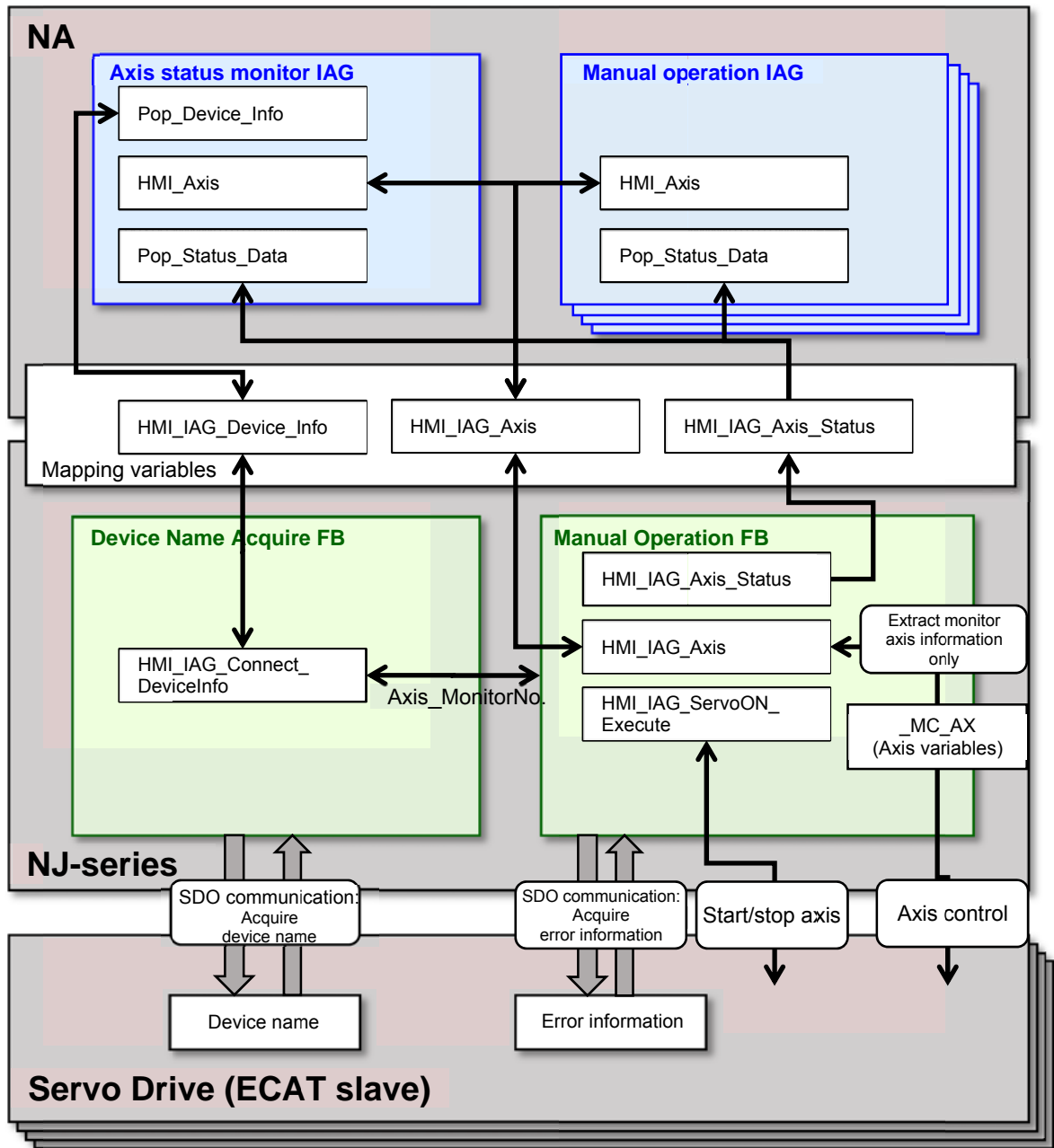

4 Use Cases

4-1 Axis Test Run Screen

You can perform a manual operation and the status monitoring of motion axes by combining and placing “Axis status monitor IAG_(Full-screen)” and “Manual operation IAG” on the page.

By placing all the objects for full-screen, you can also implement the Motion Axis Test Run screen of the Sysmac Studio. In this case, place each “manual operation object” to the “tab control object” so that all the IAGs are positioned on the same page.



Place “manual operation object” to “tab control object”.

4-2 Axis Test Run Pop-up Page

You can create a pop-up page for operating and monitoring axes by placing the pop-up objects on the pop-up page. As an example, a Jog feed screen is shown below.

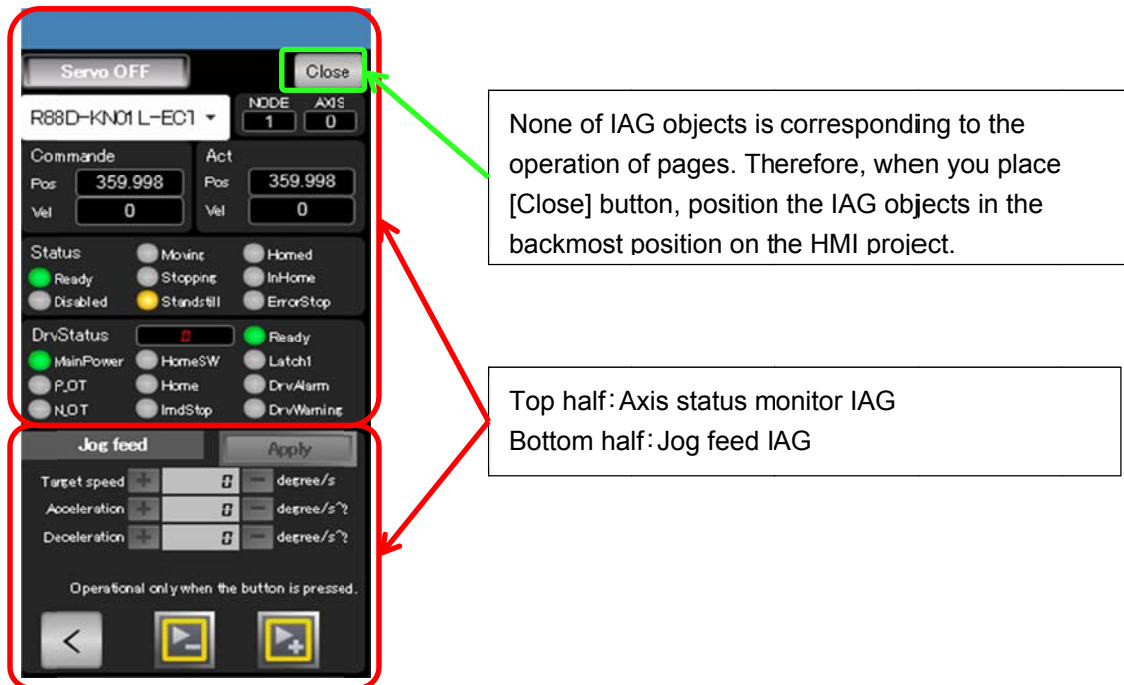

The following is a screen when a pop-up page placed with the IAG objects is displayed on top of the page for sensor thresholds. On this page, you can fine-tune the axes while monitoring the sensor thresholds.

To enable a drag-and-drop operation, select the [Movable] checkbox in Properties on the Pop-up page.

To operate the pop-up page and update its background screen, select [Modeless] for [DisplayMode].

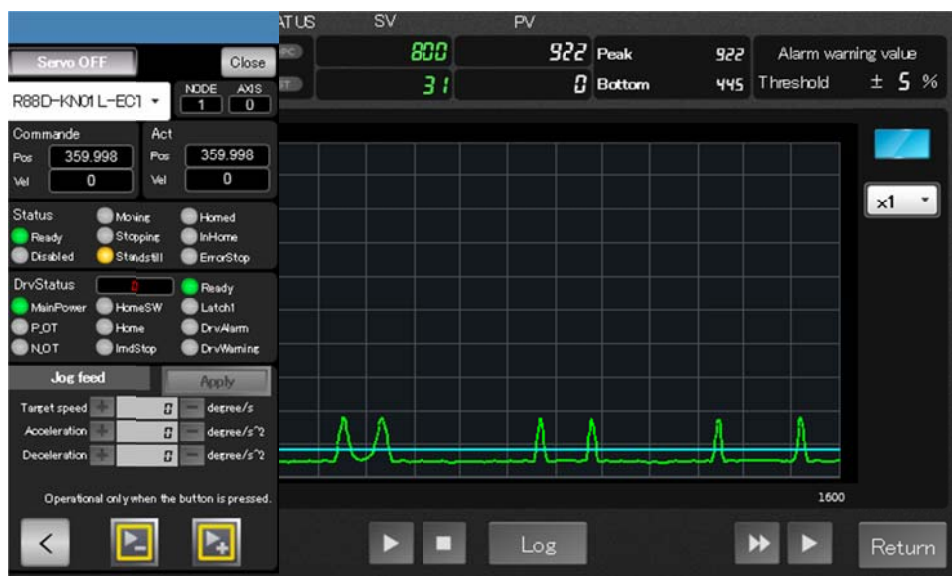

5 Details of IAG Specifications

5-1 Axis Status Monitor IAG

5-1-1 External Specification

Object name	ServoStatus
Category	IAG_MCTest_Popup *1)
Function	<ul style="list-style-type: none">• Starts (enables)/ stops (disables) the specified axis.• Switches the specified axis.• Stops the operation of specified axis (emergency stop function).• Displays the status of the specified axis.

*1) IAG category for popup page.

"IAG_MCTest_9inch" is the category for 9 inches, and "IAG_MCTest_12inch" is for 12 inches.

5-1-2 GUI

● Pop-up page



● Full-screen



No	Name	Description
1	[Servo ON/OFF] button	<ul style="list-style-type: none"> • Turns ON/ OFF the selected axis. • Enabled when Servo is OFF, disabled when servo is ON.
2	Drop-down list	<ul style="list-style-type: none"> • Shows the connected servo drives. • Select the axis you want to monitor from the list.
3	Node and Axis No.	<ul style="list-style-type: none"> • Shows the node No. and the axis No. of the selected axis.
4	Command value	<ul style="list-style-type: none"> • Shows the command value.
5	Axis feedback value	<ul style="list-style-type: none"> • Shows the axis feedback value.
6	Axis status	<ul style="list-style-type: none"> • Monitors the status of the selected axis.
7	Error code	<ul style="list-style-type: none"> • Shows the error code if there is an error during SDO communication.
8	Servo status	<ul style="list-style-type: none"> • Monitors the status of servo drive of the selected axis.

5-1-3 Properties

● Properties

Property name	Description	Input method	Range	Default
General				
Name	Specifies the object name. The name must be unique in that screen.	Direct input	String(1 to 127 characters)	ServoStatus0
Type	Specifies the object type.This item cannot be changed.	-	-	IAG
Version	Specifies the version of the IAG.	-	-	1.14A
Publisher	Specifies the IAG publisher.	-	-	Omron
Appearance				
BackgroundColor	Specifies the background color of the page.	Item selection Direct input	Color palette String	Transparent *1)
Layout				
▼Position (Left,Top)	Specifies the position of the object on the page.*2)	Direct input Spin button	Numerical Numerical	- *3)
Left	Specifies the horizontal page coordinate (x-axis) of the position of the top-left of the object.	Direct input Spin button	Numerical Numerical	-
Top	Specifies the vertical page coordinate (y-axis) of the position of the top-left of the object.	Direct input Spin button	Numerical Numerical	-
▼Size (Width,Height)	Specifies the size of the object.	Direct input Spin button	Numerical Numerical	For Pop-up:(231,268) For 9 inches:(800,282) For 12 inches:(1280,293) *3)
Width	Specifies the object width.	Direct input Spin button	Numerical Numerical	For Pop-up:231 For 9 inches:800 For 12 inches:1280
Height	Specifies the object height.	Direct input Spin button	Numerical Numerical	For Pop-up:268 For 9 inches:282 For 12 inches:293
Behavior (In/Out)				
HMI_Axis	Specifies the monitor axis information.	Direct input	Structures (_sAXIS_REF)	(Blank)
HMI_IAG_Axis_Status	Specifies the value of operation parameter.	Direct input	Structures (IAG_Param_REF)	(Blank)
Pop_Device_Info	Specifies the connected device information.	Direct input	Structures (IAG_Device_Info)	(Blank)

Properties screen

The properties of Pop-up IAG

*1)"Transparent" indicates that the colour is transparent.

*2)The coordinate origin is the upper-left corner of the NA-series PT screen.

*3)In units of pixels

- Event and action

There are no event and action functions.

- Animation

You can define the basic animation action.

Animation name	Description
Move	Changes the coordinates of the object according to specified condition expressions.
Resize Height	Changes the height of the object according to a specified condition expression.
Resize Width	Changes the width of the object according to a specified condition expression.
Visibility	Displays the object when a condition expression is met.

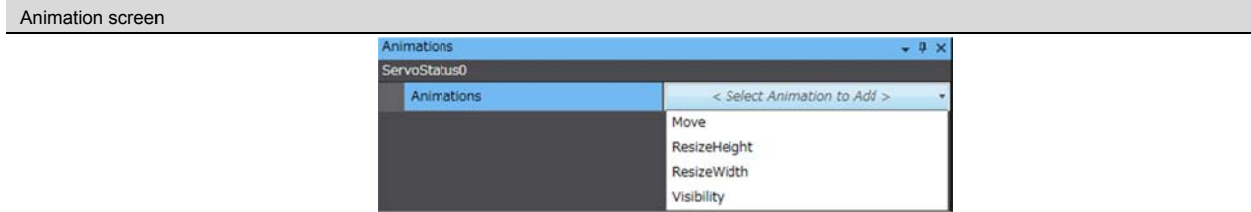

- I/O variable timing

Variable	Timing for loading input data	Timing for outputting data
HMI_Axis	<ul style="list-style-type: none"> • When executing the "List_ItemSet" subroutine. • When changing a drop-down list item. 	<ul style="list-style-type: none"> • When the [Servo ON/OFF] button is being pressed. • When [Deceleration stop] button is being pressed.
Pop_Status_Data	<ul style="list-style-type: none"> • When executing the "List_ItemSet" subroutine. • When changing a drop-down list item. • When there is an error. 	Constantly
Pop_Device_Info	<ul style="list-style-type: none"> • When executing the "List_ItemSet" subroutine. • When changing a drop-down list item. 	Constantly

5-1-4 Features

- Among the EtherCAT devices connected to the NJ, only servo drives are displayed in the drop-down list and corresponded to the axis No.
- To display the connected servo drives, press the drop-down list.
*The servo drive with the smallest node No. is shown by default.
- Select any servo drive from the drop-down list, and then the status of the servo drive is displayed in the display area.
- To turn ON/ OFF the selected servo drive, press the [Servo ON/OFF] button.
- To decelerate and stop the selected servo drive, press the [Deceleration stop] button during the servo operation.
- If there is an error during manual operation, the error code is displayed in the display area of servo status.

5-2 Jog Feed IAG

5-2-1 External Specification

Object name	JogFeed
Category	IAG_MCTest_Popup *1)
Function	<ul style="list-style-type: none">· Sets parameters for jog speed of the specified axis and others.· Moves the specified axis in forward/reverse direction.

*1) IAG category for popup page.

"IAG_MCTest_9inch" is the category for 9 inches, and "IAG_MCTest_12inch" is for 12 inches.

5-2-2 GUI

● Pop-up page

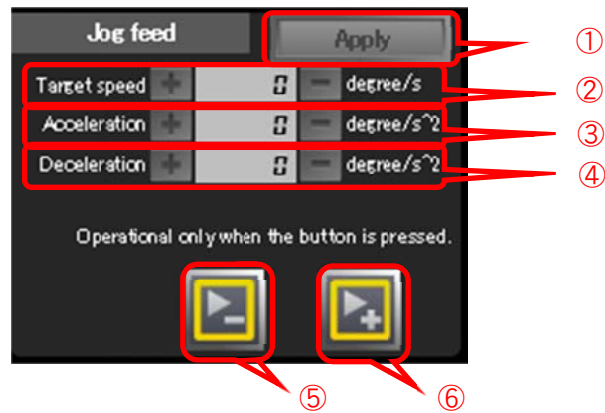

● Full-screen

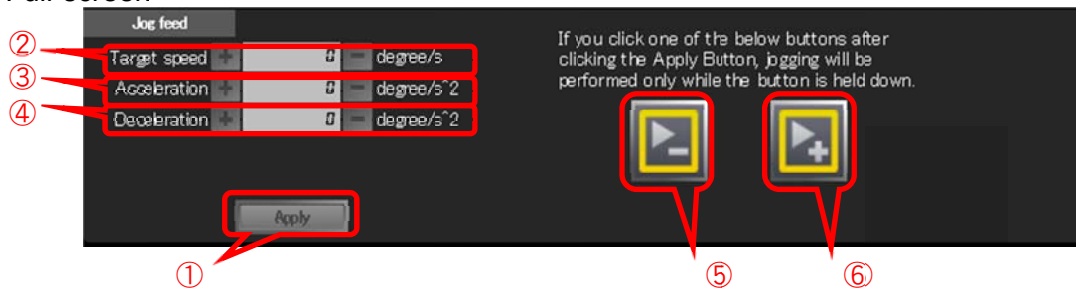

No	Name	Description
1	[Apply] button	<ul style="list-style-type: none"> Applies the target speed, acceleration, and deceleration that you entered to the selected axis.
2	Target speed	<ul style="list-style-type: none"> Sets the target speed. To directly enter set values, use the numeric keypad that will be displayed by pressing in the numeral display area. To increment/decrement the set value, press the [+] /[-] button.
3	Acceleration	<ul style="list-style-type: none"> Sets the acceleration. To directly enter set values, use the numeric keypad that will be displayed by pressing in the numeral display area. To increment/decrement the set value, press the [+] /[-] button.
4	Deceleration	<ul style="list-style-type: none"> Sets the deceleration. To directly enter set values, use the numeric keypad that will be displayed by pressing in the numeral display area. To increment/decrement the set value, press the [+] /[-] button.
5	[Reverse operation] button	<ul style="list-style-type: none"> The servomotor moves in the reverse direction according to the setting.
6	[Forward operation] button	<ul style="list-style-type: none"> The servomotor moves in the forward direction according to the setting.

5-2-3 Properties

● Properties

Property name	Description	Input method	Range	Default
General				
Name	Specifies the object name. The name must be unique in that screen.	Direct input	String(1 to 127 characters)	JogFeed0
Type	Specifies the object type.This item cannot be changed.	-	-	IAG
Version	Specifies the version of the IAG.	-	-	1.14A
Publisher	Specifies the IAG publisher.	-	-	Omron
Appearance				
BackgroundColor	Specifies the background color of the page.	Item selection Direct input	Color palette String	Transparent *1)
Layout				
▼Position (Left,Top)	Specifies the position of the object on the page. *2)	Direct input Spin button	Numerical Numerical	- *3)
Left	Specifies the horizontal page coordinate (x-axis) of the position of the top-left of the object.	Direct input Spin button	Numerical Numerical	-
Top	Specifies the vertical page coordinate (y-axis) of the position of the top-left of the object.	Direct input Spin button	Numerical Numerical	-
▼Size (Width,Height)	Specifies the size of the object.	Direct input Spin button	Numerical Numerical	For Pop-up:(231,176) For 9 inches:(800,176) For 12 inches:(1280,293) *3)
Width	Specifies the object width.	Direct input Spin button	Numerical Numerical	For Pop-up:231 For 9 inches:800 For 12 inches:1280
Height	Specifies the object height.	Direct input Spin button	Numerical Numerical	For Pop-up:176 For 9 inches:176 For 12 inches:293
Behavior (In/Out)				
HMI_Axis	Specifies the monitor axis information.	Direct input	Structures (_sAXIS_REF)	(Blank)
HMI_IAG_Axis_Status	Specifies the value of operation parameter.	Direct input	Structures (IAG_Param_REF)	(Blank)

Properties screen

General	
Name	JogFeed0
Type	IAG
Version	1.14A
Publisher	Omron
Appearance	
BackgroundColor	<input type="checkbox"/> Transparent
Layout	
▼ Position (Left,Top)	0, 0
Left	0
Top	0
▼ Size (Width,Height)	231, 176
Width	231
Height	176
Behavior (In/Out)	
HMI_Axis	
Pop_Status_Data	

The properties of Pop-up IAG

*1)"Transparent" indicates that the colour is transparent.

*2)The coordinate origin is the upper-left corner of the NA-series PT screen.

*3)In units of pixels

- Event and action

There are no event and action functions.

- Animation

You can define the basic animation action.

Animation name	Description
Move	Changes the coordinates of the object according to specified condition expressions.
Resize Height	Changes the height of the object according to a specified condition expression.
Resize Width	Changes the width of the object according to a specified condition expression.
Visibility	Displays the object when a condition expression is met.

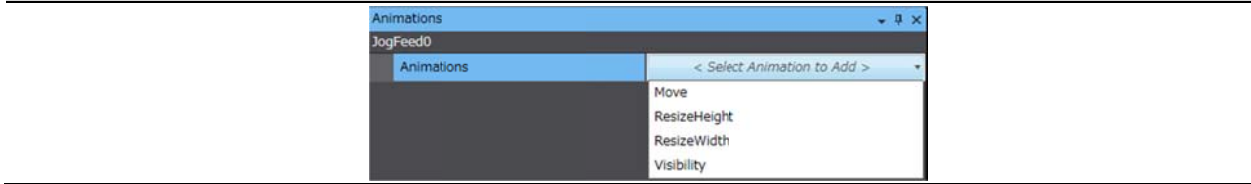

- I/O variable timing

Variable	Input timing	Output timing
HMI_Axis	.	<ul style="list-style-type: none"> • When [Forward operation] button is being pressed. • When [Reverse operation] button is being pressed.
Pop_Status_Data	.	<ul style="list-style-type: none"> • When [Apply] button is being pressed.

5-2-4 Features

- To directly enter set values, use the numeric keypad that will be displayed by pressing in the numeral display area for each setting.
- To increment/decrement the set value, press the [+] /[-] button in each setting.
- The [Apply] button is enabled after changing the set value.
- To apply the set value to the selected axis, press the [Apply] button.
- The operation button of each direction is enabled by pressing the [Apply] button.
- While the [Forward operation]/[Reverse operation] button is being pressed, the rotation speed for servomotor will be accelerated at the set acceleration speed until it reaches the target speed.
- When the [Forward operation]/[Reverse operation] button is released, the rotation speed for servomotor will be decelerated at the set deceleration speed until the servomotor stops.

5-3 Absolute Positioning IAG

5-3-1 External Specification

Object name	AbsolutePositioning
Category	IAG_MCTest_Popup *1)
Function	<ul style="list-style-type: none">• Sets parameters for absolute positioning speed of the specified axis and others.• Performs the absolute positioning of the specified axis.• Stops the absolute positioning of the specified axis.

*1) IAG category for popup page.

"IAG_MCTest_9inch" is the category for 9 inches, and "IAG_MCTest_12inch" is for 12 inches.

5-3-2 GUI

● Pop-up page



● Full-screen

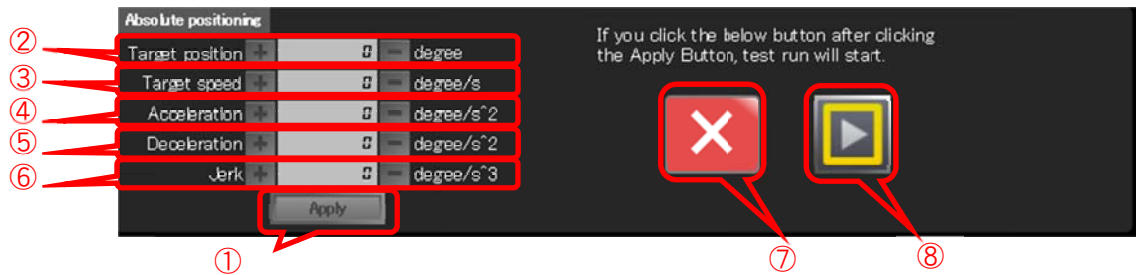

No	Name	Description
1	[Apply] button	<ul style="list-style-type: none"> Applies the target position, target speed, acceleration, deceleration, and Jerk that you entered to the selected axis.
2	Target position	<ul style="list-style-type: none"> Sets the target position. To directly enter set values, use the numeric keypad that will be displayed by pressing in the numeral display area. To increment/decrement the set value, press the [+] /[-] button.
3	Target speed	<ul style="list-style-type: none"> Sets the target speed. To directly enter set values, use the numeric keypad that will be displayed by pressing in the numeral display area. To increment/decrement the set value, press the [+] /[-] button.
4	Acceleration	<ul style="list-style-type: none"> Sets the acceleration. To directly enter set values, use the numeric keypad that will be displayed by pressing in the numeral display area. To increment/decrement the set value, press the [+] /[-] button.
5	Deceleration	<ul style="list-style-type: none"> Sets the deceleration. To directly enter set values, use the numeric keypad that will be displayed by pressing in the numeral display area. To increment/decrement the set value, press the [+] /[-] button.
6	Jerk	<ul style="list-style-type: none"> Sets the Jerk. To directly enter set values, use the numeric keypad that will be displayed by pressing in the numeral display area. To increment/decrement the set value, press the [+] /[-] button.
7	[Deceleration stop] button	<ul style="list-style-type: none"> Decelerates and stops the servomotor.
8	[Operation] button	<ul style="list-style-type: none"> Moves the servomotor to the target position according to the setting.

5-3-3 Properties

● Properties

Property name	Description	Input method	Range	Default
General				
Name	Specifies the object name. The name must be unique in that screen.	Direct input	String(1 to 127 characters)	AbsolutePositioning0
Type	Specifies the object type.This item cannot be changed.	-	-	IAG
Version	Specifies the version of the IAG.	-	-	1.14A
Publisher	Specifies the IAG publisher.	-	-	Omron
Appearance				
BackgroundColor	Specifies the background color of the page.	Item selection Direct input	Color palette String	Transparent *1)
Layout				
▼Position (Left,Top)	Specifies the position of the object on the page. *2)	Direct input Spin button	Numerical Numerical	- *3)
Left	Specifies the horizontal page coordinate (x-axis) of the position of the top-left of the object.	Direct input Spin button	Numerical Numerical	-
Top	Specifies the vertical page coordinate (y-axis) of the position of the top-left of the object.	Direct input Spin button	Numerical Numerical	-
▼Size (Width,Height)	Specifies the size of the object.	Direct input Spin button	Numerical Numerical	For Pop-up:(231,176) For 9 inches:(800,176) For 12 inches:(1280,293) *3)
Width	Specifies the object width.	Direct input Spin button	Numerical Numerical	For Pop-up:231 For 9 inches:800 For 12 inches:1280
Height	Specifies the object height.	Direct input Spin button	Numerical Numerical	For Pop-up:176 For 9 inches:176 For 12 inches:293
Behavior (In/Out)				
HMI_Axis	Specifies the monitor axis information.	Direct input	Structures (_sAXIS_REF)	(Blank)
HMI_IAG_Axis_Status	Specifies the value of operation parameter.	Direct input	Structures (IAG_Param_REF)	(Blank)

Properties screen

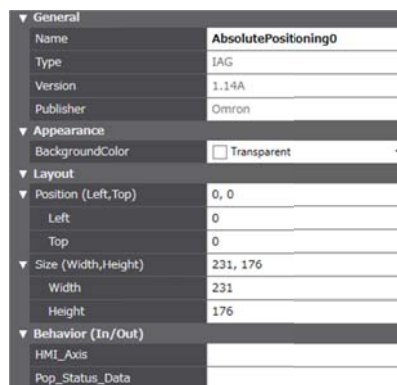

The properties of Pop-up IAG

*1)"Transparent" indicates that the colour is transparent.

*2)The coordinate origin is the upper-left corner of the NA-series PT screen.

*3)In units of pixels

- Event and action

There are no event and action functions.

- Animation

You can define the basic animation action.

Animation name	Description
Move	Changes the coordinates of the object according to specified condition expressions.
Resize Height	Changes the height of the object according to a specified condition expression.
Resize Width	Changes the width of the object according to a specified condition expression.
Visibility	Displays the object when a condition expression is met.

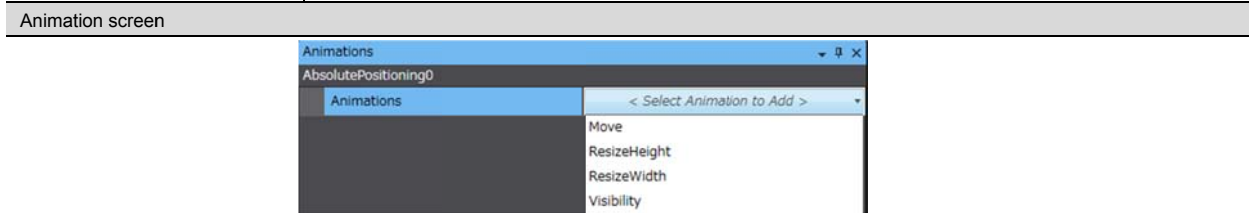

- I/O variable timing

Variable	Input timing	Output timing
HMI_Axis	.	<ul style="list-style-type: none"> • When [Operation] button is being pressed. • When [Deceleration stop] button is being pressed.
Pop_Status_Data	.	<ul style="list-style-type: none"> • When [Apply] button is being pressed.

5-3-4 Features

- To directly enter set values, use the numeric keypad that will be displayed by pressing in the numeral display area for each setting.
- To increment/decrement the set value, press the [+] /[-] button in each setting.
- The [Apply] button is enabled after changing the set value.
- To apply the set value to the selected axis, press the [Apply] button.
- The [Operation] button is enabled after pressing the [Apply] button.
- While the [Operation] button is being pressed, the servomotor keeps rotating until it reaches the target position.
- The servomotor accelerates at the acceleration speed until it reaches the target speed, and decelerates at the deceleration speed to stop at the set target position.
 - * The servomotor may not reach the target speed depending on the set acceleration speed and the target speed.
- The acceleration/deceleration ratio varies depending on the Jerk setting.
- To decelerate and stop the servomotor, pressing the [Deceleration stop] button.

5-4 Relative Positioning IAG

5-4-1 External Specification

Object name	RelativePositioning
Category	IAG_MCTest_Popup *1)
Function	<ul style="list-style-type: none">· Sets parameters for relative positioning speed of the specified axis and others.· Performs the relative positioning of the specified axis.· Stops the relative positioning of the specified axis.

*1) IAG category for popup page.

"IAG_MCTest_9inch" is the category for 9 inches, and "IAG_MCTest_12inch" is for 12 inches.

5-4-2 GUI

● Pop-up page



● Full-screen

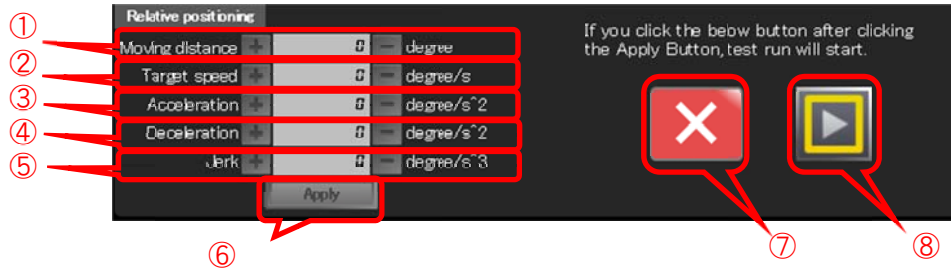

No	Name	Description
1	[Apply] button	<ul style="list-style-type: none"> Applies the moving distance, target speed, acceleration, deceleration, and Jerk that you entered to the selected axis.
2	Moving distance	<ul style="list-style-type: none"> Sets the moving distance. To directly enter set values, use the numeric keypad that will be displayed by pressing in the numeral display area. To increment/decrement the set value, press the [+] /[-] button.
3	Target speed	<ul style="list-style-type: none"> Sets the target speed. To directly enter set values, use the numeric keypad that will be displayed by pressing in the numeral display area. To increment/decrement the set value, press the [+] /[-] button.
4	Acceleration	<ul style="list-style-type: none"> Sets the acceleration. To directly enter set values, use the numeric keypad that will be displayed by pressing in the numeral display area. To increment/decrement the set value, press the [+] /[-] button.
5	Deceleration	<ul style="list-style-type: none"> Sets the deceleration. To directly enter set values, use the numeric keypad that will be displayed by pressing in the numeral display area. To increment/decrement the set value, press the [+] /[-] button.
6	Jerk	<ul style="list-style-type: none"> Sets the Jerk. To directly enter set values, use the numeric keypad that will be displayed by pressing in the numeral display area. To increment/decrement the set value, press the [+] /[-] button.
7	[Deceleration stop] button	<ul style="list-style-type: none"> Decelerates and stops the servomotor.
8	[Operation] button	<ul style="list-style-type: none"> Operates the servomotor according to the setting.

5-4-3 Properties

● Properties

Property name	Description	Input method	Range	Default
General				
Name	Specifies the object name. The name must be unique in that screen.	Direct input	String(1 to 127 characters)	RelativePositioning0
Type	Specifies the object type.This item cannot be changed.	-	-	IAG
Version	Specifies the version of the IAG.	-	-	1.14A
Publisher	Specifies the IAG publisher.	-	-	Omron
Appearance				
BackgroundColor	Specifies the background color of the page.	Item selection Direct input	Color palette String	Transparent *1)
Layout				
▼Position (Left,Top)	Specifies the position of the object on the page. *2)	Direct input Spin button	Numerical Numerical	- *3)
Left	Specifies the horizontal page coordinate (x-axis) of the position of the top-left of the object.	Direct input Spin button	Numerical Numerical	-
Top	Specifies the vertical page coordinate (y-axis) of the position of the top-left of the object.	Direct input Spin button	Numerical Numerical	-
▼Size (Width,Height)	Specifies the size of the object.	Direct input Spin button	Numerical Numerical	For Pop-up:(231,176) For 9 inches:(800,176) For 12 inches:(1280,293) *3)
Width	Specifies the object width.	Direct input Spin button	Numerical Numerical	For Pop-up:231 For 9 inches:800 For 12 inches:1280
Height	Specifies the object height.	Direct input Spin button	Numerical Numerical	For Pop-up:176 For 9 inches:176 For 12 inches:293
Behavior (In/Out)				
HMI_Axis	Specifies the monitor axis information.	Direct input	Structures (_sAXIS_REF)	(Blank)
HMI_IAG_Axis_Status	Specifies the value of operation parameter.	Direct input	Structures (IAG_Param_REF)	(Blank)

Properties screen

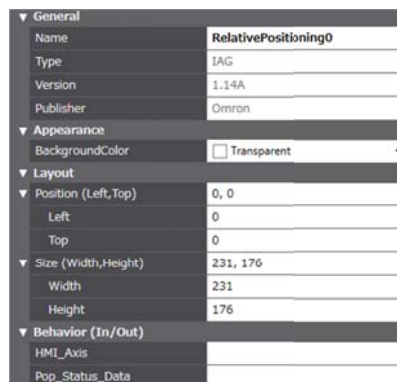

The properties of Pop-up IAG

*1)"Transparent" indicates that the colour is transparent.

*2)The coordinate origin is the upper-left corner of the NA-series PT screen.

*3)In units of pixels

- Event and action

There are no event and action functions.

- Animation

You can define the basic animation action.

Animation name	Description
Move	Changes the coordinates of the object according to specified condition expressions.
Resize Height	Changes the height of the object according to a specified condition expression.
Resize Width	Changes the width of the object according to a specified condition expression.
Visibility	Displays the object when a condition expression is met.

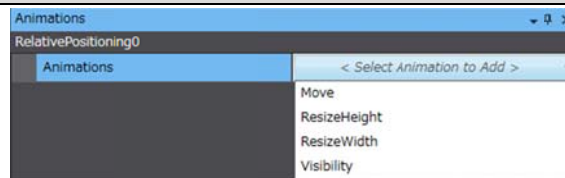

- I/O variable timing

Variable	Input timing	Output timing
HMI_Axis	.	<ul style="list-style-type: none"> • When [Operation] button is being pressed. • When [Deceleration stop] button is being pressed.
Pop_Status_Data	.	<ul style="list-style-type: none"> • When [Apply] button is being pressed.

5-4-4 Features

- To directly enter set values, use the numeric keypad that will be displayed by pressing in the numeral display area for each setting.
- To increment/decrement the set value, press the [+] /[-] button in each setting.
- The [Apply] button is enabled after changing the set value.
- To apply the set value to the selected axis, press the [Apply] button.
- The [Operation] button is enabled after pressing the [Apply] button.
- While the [Operation] button is being pressed, the servomotor keeps rotating by the set moving distance.
- The servomotor accelerates at the acceleration speed until it reaches the target speed, and decelerates at the deceleration speed to stop at the set moving distance.
 - * The servomotor may not reach the target speed depending on the set acceleration speed and the target speed.
- The acceleration/deceleration ratio varies depending on the Jerk setting.
- To decelerate and stop the servomotor, press the [Deceleration stop] button.

5-5 Homing IAG

5-5-1 External Specification

Object name	Homing
Category	IAG_MCTest_Popup *1)
Function	<ul style="list-style-type: none">· Performs homing of the specified axis.· Stops homing of the specified axis.

*1) IAG category for popup page.

"IAG_MCTest_9inch" is the category for 9 inches, and "IAG_MCTest_12inch" is for 12 inches.

5-5-2 GUI

● Pop-up page

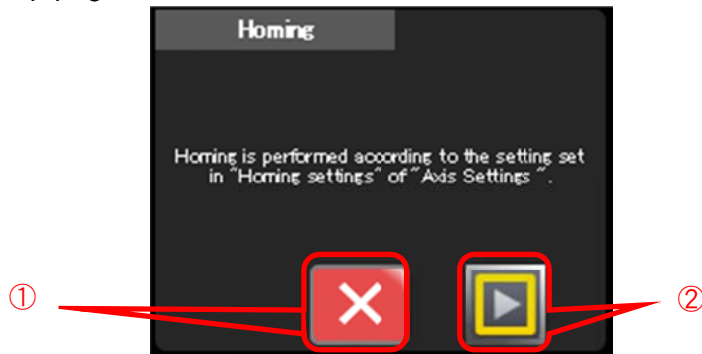

● Full-screen

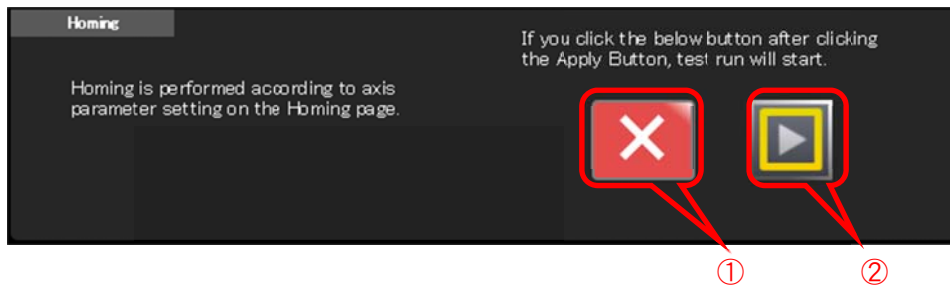

No	Name	Description
1	[Deceleration stop] button	<ul style="list-style-type: none">• Decelerates and stops the servomotor.
2	[Operation] button	<ul style="list-style-type: none">• Returns the servomotor to its home position.

5-5-3 Properties

● Properties

Property name	Description	Input method	Range	Default
General				
Name	Specifies the object name. The name must be unique in that screen.	Direct input	String(1 to 127 characters)	Homing0
Type	Specifies the object type.This item cannot be changed.	-	-	IAG
Version	Specifies the version of the IAG.	-	-	1.14A
Publisher	Specifies the IAG publisher.	-	-	Omron
Appearance				
BackgroundColor	Specifies the background color of the page.	Item selection Direct input	Color palette String	Transparent *1)
Layout				
▼Position (Left,Top)	Specifies the position of the object on the page. *2)	Direct input Spin button	Numerical Numerical	- *3)
Left	Specifies the horizontal page coordinate (x-axis) of the position of the top-left of the object.	Direct input Spin button	Numerical Numerical	-
Top	Specifies the vertical page coordinate (y-axis) of the position of the top-left of the object.	Direct input Spin button	Numerical Numerical	-
▼Size (Width,Height)	Specifies the size of the object.	Direct input Spin button	Numerical Numerical	For Pop-up:(231,176) For 9 inches:(800,176) For 12 inches:(1280,293) *3)
Width	Specifies the object width.	Direct input Spin button	Numerical Numerical	For Pop-up:231 For 9 inches:800 For 12 inches:1280
Height	Specifies the object height.	Direct input Spin button	Numerical Numerical	For Pop-up:176 For 9 inches:176 For 12 inches:293
Behavior (In/Out)				
HMI_Axis	Specifies the monitor axis information.	Direct input	Structures (_sAXIS_REF)	(Blank)
HMI_IAG_Axis_Status	Specifies the value of operation parameter.	Direct input	Structures (IAG_Param_REF)	(Blank)

Properties screen

The properties of Pop-up IAG

*1)"Transparent" indicates that the colour is transparent.

*2)The coordinate origin is the upper-left corner of the NA-series PT screen.

*3)In units of pixels

- Event and action

There are no event and action functions.

- Animation

You can define the basic animation action.

Animation name	Description
Move	Changes the coordinates of the object according to specified condition expressions.
Resize Height	Changes the height of the object according to a specified condition expression.
Resize Width	Changes the width of the object according to a specified condition expression.
Visibility	Displays the object when a condition expression is met.

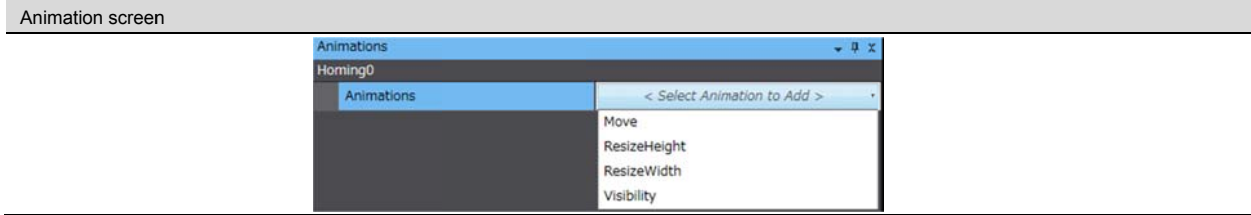

- I/O variable timing

Variable	Input timing	Output timing
HMI_Axis	.	<ul style="list-style-type: none"> • When [Operation] button is being pressed. • When [Deceleration stop] button is being pressed.
Pop_Status_Data	.	

5-5-4 Features

- To return the servomotor to its home position, press the [Operation] button.
- To decelerate and stop the servomotor, press the [Deceleration stop] button.
- You can view the status of homing in the display area of axis status monitor IAG.

6 Details of FB Specifications

6-1 Axis Information Acquire FB

6-1-1 External Specification

Instruction	Name	FB/ FUN	Graphic expression	ST expressions
HMI_IAG_Init_FB	Acquiring axis information	FB		<pre>HMI_IAG_Init_instance(Execute:= 《parameter》, Done=> 《parameter》, Busy=> 《parameter》, Error=> 《parameter》, ErrorID=> 《parameter》, ErrorID_Ex=> 《parameter》);</pre>

6-1-2 Input Variable

Input variable	Name	Data type	Valid range	Default	Description
Execute	Start	BOOL	TRUE, FALSE	FALSE	The instruction is executed when Execute changes to TRUE.

6-1-3 Output Variable

Input variable	Name	Data type	Valid range	Description
Done	Done	BOOL	TRUE, FALSE	TRUE when the instruction is completed.
Busy	During execution	BOOL	TRUE, FALSE	TRUE when the instruction is acknowledged.
Error	Error	BOOL	TRUE, FALSE	TRUE while there is an error.
ErrorID	Error code	WORD	*	Outputs the error code when an error occurs. Outputs 16#0000 under normal operation.
ErrorID_Ex	Expansion error code	DWORD	*	Outputs the expansion error code when an error occurs. Outputs 16#0000 under normal operation.

● Output variable update timing

Variable	Timing for changing to TRUE	Timing for changing to FALSE
Done	When the instruction is completed.	<ul style="list-style-type: none"> One period after Busy changes to FALSE.
Busy	When Execute changes to TRUE.	<ul style="list-style-type: none"> Done changes to TRUE. Error changes to TRUE.
Error	When there is an error in the execution conditions or input parameters for the instruction.	When the error is cleared.

6-1-4 External Variable

External Variable	Name	Data type	Valid range	Description
HMI_IAG_Connect_DeviceInfo	Specifies the connected device information.	IAG_Device_Info *1	*	Information of the devices connected to PLC with EtherCAT communications.
_EC_NetCfgErr *2	Network configuration information error	BOOL	TRUE, FALSE	TRUE if there is illegal network configuration information.
_EC_MBXSlavTbl *2	Message communications enabled slave table	ARRAY [1..192] OF BOOL	TRUE, FALSE	A list of slaves that can perform message communications. Slaves are given in the table in the order of slave node addresses. The element for a slave is TRUE if message communications are enabled for it (pre-operational, safe-operation, or operational state).
_MC_AX *3	Axis variables	ARRAY [0..63] OF _sAxis_REF	*	Axis Variables are system-defined variables for some of the axis parameters and for the monitor information, such as the actual position and error information for the axes controlled by the MC Function Module.

*1 For details on data type of [IAG_Device_Info], refer to *section 7* of this guide.

*2 For details on variable of [_EC_NetCfgErr] and [_EC_MBXSlavTbl], refer to *NJ/NX-series CPU Unit Built-in EtherCAT® Port User's Manual* (Cat. No. W505).

*3 For details on variable of [_MC_AX], refer to *NJ/NX-series CPU Unit Motion Control User's Manual* (Cat. No. W507).

6-1-5 Features

- Extracts the node number of the devices connected to the NJ via the EtherCAT communications.
- Associates the axis number with the node number.
- Extracts the device name of the devices connected to the NJ via the EtherCAT communications.

6-2 Manual Operation FB

6-2-1 External Specification

Instruction	Name	FB/ FUN	Graphic expression	ST expressions
HMI_IAG_Axis_FB	Manual operation	FB		<pre>HMI_IAG_Axis_instance(Execute: = 《parameter》, Home_TriggerVariable: = 《parameter》, Busy=> 《parameter》, Axis_MonitorNo: = 《parameter》);</pre>

6-2-2 Input Variable

Input variable	Name	Data type	Valid range	Default	Description
Execute	Start	BOOL	TRUE, FALSE	FALSE	The instruction is executed when Execute changes to TRUE.
Home_TriggerVariable	Home signal for external input	BOOL	TRUE, FALSE	FALSE	Specifies the home input signal for homing.

6-2-3 Output Variable

Input variable	Name	Data type	Valid range	Description
Busy	During execution	BOOL	TRUE, FALSE	TRUE when the instruction is acknowledged.

● Output variable update timing

Variable	Timing for changing to TRUE	Timing for changing to FALSE
Busy	<ul style="list-style-type: none"> When executing the stop processing When performing the absolute positioning When performing the relative positioning When performing the homing 	<ul style="list-style-type: none"> When terminating the stop processing When terminating the absolute positioning When terminating the relative positioning When terminating the homing

6-2-4 I/O Variable

Input variable	Name	Data type	Valid range	Description
Axis_MonitorNo	Monitor axis No.	UINT	*	No. of axis that is being monitored. Connects with HMI_IAG_Connect_DeviceInfo.Axis_MonitorNo. of Axis Information Acquire FB.

6-2-5 External Variable

External Variable	Name	Data type	Valid range	Description
_MC_AX *1	Axis variables	ARRAY [0..63] OF _sAxis_ REF	*	System-defined variables for some of the axis parameters and for the monitor information, such as the actual position and error information for the axes controlled by the MC Function Module.
HMI_IAG_Axis	Monitor axis information.	_sAxis_ REF	*	Some of the axes which is being monitored with IAG, and the monitor information, such as the actual position and error information.
HMI_IAG_Axis_Status	Jog feed status	IAG_Param_REF *2	*	The set value and error code of each operation for MC Test Run.
_EC_PDslavTbl *3	Process data communicating slave table	ARRAY [1..192] OF BOOL	TRUE FALSE	A list of slaves that are performing process data communications. Slaves are given in the table in the order of slave node addresses. The element for a slave is TRUE if process data of the corresponding slave is enabled (operational) for both slave inputs and outputs.
_EC_CommErrTbl *3	Communications error slave table	ARRAY [1..192] OF BOOL	TRUE FALSE	Slaves are given in the table in the order of slave node addresses. The corresponding slave element is TRUE if the master detected an error for the slave.
HMI_IAG_ServoON_Execute	IAG selected axis start	ARRAY [0..63] OF BOOL	TRUE FALSE	Execute Flag of axis selected with IAG. TRUE when axis is executed.

*1 For details on variable of [_MC_AX], refer to *NJ/NX-series CPU Unit Motion Control User's Manual* (Cat. No. W507).

*2 For details on data type of [IAG_Param_REF], refer to *section 7* of this guide.

*3 For details on variable of [_EC_PDslavTbl], [_EC_CommErrTbl], refer to *NJ/NX-series CPU Unit Motion Control User's Manual* (Cat. No. W507).

6-2-6 Features

- Performs the jog feeding.
- Performs the absolute positioning.
- Performs the relative positioning.
- Performs the homing.
- Performs the deceleration stop.

7 Details of Variable Specifications

7-1 Structures Registered in FB Library of NJ

7-1-1 Axis Information Acquire FB

Variable name	Data type	Name	Function
IAG_Device_Info	STRUCT	Structures for connected device information.	
Axis_MonitorNo	UINT	Monitor axis No.	An axis number of the device to be monitored.
Connect_NodeNo	ARRAY[0..199] OF STRING[10]	Connected node No.	A node number of the connected device.
Device_Name	ARRAY[0..199] OF STRING[50]	Connected device name	A name of the connected device.
Device_Count	UINT	Number of connected devices	The number of the connected devices.
Axis_Tbl_AxisNo	ARRAY[0..255] OF UINT	Information of connected axis No.	A variable for retaining the valid axis number.
Axis_Tbl_NodeNo	ARRAY[0..255] OF UINT	Information of node No. in order of connected axis	A variable for retaining the valid node number.
Select_NodeNo	ARRAY[0..199] OF STRING[50]	Servo-recognized node No.	A node number of the connected servo.
First_Chk	BOOL	Flag for checking the after-startup connection status	Flag for checking the connection status.

7-1-2 Manual Operation FB

Variable name	Data type	Name	Function
IAG_Param_REF	STRUCT	Structures for status of jog feed.	
Velocity	LREAL	Target speed	The target speed during the operation of servomotor.
Acceleration	LREAL	Acceleration	The acceleration during the operation of servomotor.
Deceleration	LREAL	Deceleration	The deceleration during the operation of servomotor.
Jerk	LREAL	Jerk	The jerk during the operation and deceleration stop of servomotor.
Position	LREAL	Target position	The target position for decelerating and stopping the servomotor.
Distance	LREAL	Moving distance	The distance for moving the servomotor.
Execute	BOOL	Operation start request	An operation start request for the servomotor.
Posi_Nega	BOOL	Operation direction(False = Posi /True = Nega)	The direction of rotating the servomotor.
ServoStop	BOOL	Servo stop request	A stop request for the servomotor.
ServoOn	BOOL	Servo ON request	A request for turning ON the servomotor.
Function_Flg	UINT	Function flag(1=Jog ,2=Absolute , 2=Relative ,4=Homing ,)	A selection flag for MC Test Run function to be executed.
Stop_Error	BOOL	Stop error	An error flag when executing the stop processing.
Abs_Error	BOOL	Absolute positioning error	An error flag when performing the absolute positioning.
Rel_Error	BOOL	Relative positioning error	An error flag when performing the relative positioning.
Home1_Error	BOOL	Home position 1 error	An error flag when homing with external signal.
Home2_Error	BOOL	Home position 2 error	An error flag when homing.
Stop_ErrorID	WORD	Stop error code	An error code when executing the stop processing.
Abs_ErrorID	WORD	Absolute positioning error code	An error code when performing the absolute positioning.
Rel_ErrorID	WORD	Relative positioning error code	An error code when performing the relative positioning.
Home1_ErrorID	WORD	Homing 1 error code	An error code when homing with external signal.
Home2_ErrorID	WORD	Homing 2 error code	An error code when homing.

7-2 Structures Registered in IAG Object of NA

The same structures as that of FB for NJ are registered.
(The data types conform to NA)

Variable name	Data type	Name	Function
IAG_Device_Info	STRUCT	Structures for connected device information.	
Axis_MonitorNo	UShort	Monitor axis No.	An axis number of the device to be monitored.
Connect_NodeNo	String(199)	Connected node No.	A node number of the connected device.
Device_Name	String(199)	Connected device name	A name of the connected device.
Device_Count	UShort	Number of connected devices	The number of the connected devices.
Axis_Tbl_AxisNo	UShort(255)	Information of connected axis No.	A variable for storing the valid axis number.
Axis_Tbl_NodeNo	UShort(255)	Information of node No. in order of connected axis	A variable for storing the valid node number.
Select_NodeNo	String(199)	Servo-recognized node No.	A node number of the connected servo.
First_Chk	Boolean	Flag for checking the after-startup connection status	A Flag for checking the after-startup connection status.

Variable name	Data type	Name	Function
IAG_Param_REF	STRUCT	Structures for status of jog feed.	
Velocity	Double	Target speed	The target speed during the operation of servomotor.
Acceleration	Double	Acceleration	The acceleration during the operation of servomotor.
Deceleration	Double	Deceleration	The deceleration during the operation of servomotor.
Jerk	Double	Jerk	The jerk during the operation and deceleration stop of servomotor.
Position	Double	Target position	The target position for decelerating and stopping the servomotor.
Distance	Double	Moving distance	The distance for moving the servomotor.
Execute	Boolean	Operation start request	An operation start request for the servomotor.
Posi_Nega	Boolean	Operation direction(False = Posi / True = Nega)	The direction of rotating the servomotor.
ServoStop	Boolean	Servo stop request	A stop request for the servomotor.
ServoOn	Boolean	Servo ON request	A request for turning ON the servomotor.
Function_Flg	UShort	Function flag(1=Jog , 2=Absolute , 2=Relative , 4=Homing ,)	A selection flag for MC Test Run function to be executed.
Stop_Error	Boolean	Stop error	An error flag when executing the stop processing.
Abs_Error	Boolean	Absolute positioning error	An error flag when performing the absolute positioning.
Rel_Error	Boolean	Relative positioning error	An error flag when performing the relative positioning.
Home1_Error	Boolean	Home position 1 error	An error flag when homing with external signal.
Home2_Error	Boolean	Home position 2 error	An error flag when homing.
Stop_ErrorID	UShort	Stop error code	An error code when executing the stop processing.
Abs_ErrorID	UShort	Absolute positioning error code	An error code when performing the absolute positioning.
Rel_ErrorID	UShort	Relative positioning error code	An error code when performing the relative positioning.
Home1_ErrorID	UShort	Homing 1 error code	An error code when homing with external signal.
Home2_ErrorID	UShort	Homing 2 error code	An error code when homing.

8 Install Procedure

You can use the IAG files and FB library files by importing them and making simple settings.

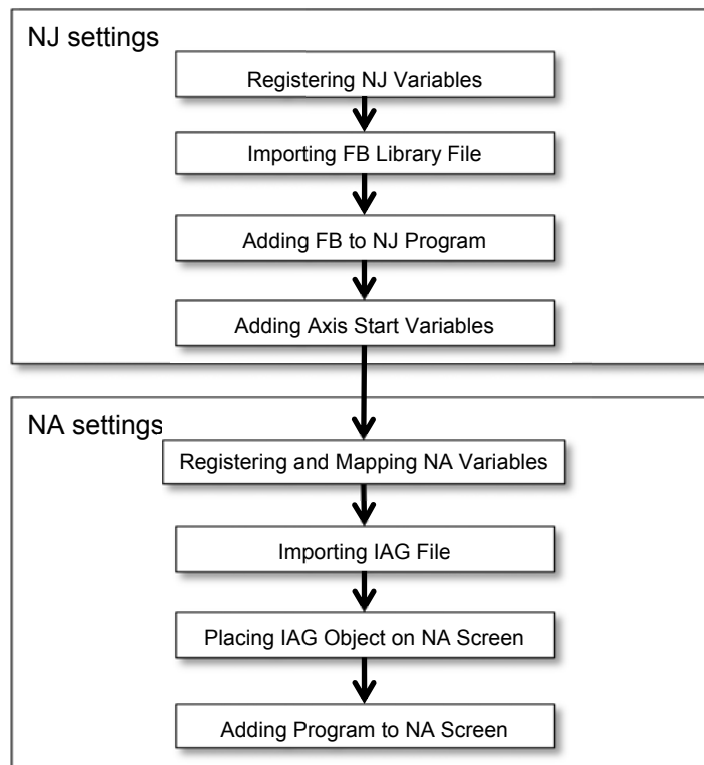

The detailed procedures are listed on the following pages.

Precautions for Correct Use

This guide assumes that parameters and axes for each servo drive have been set properly. Check these settings thoroughly before installation.

For how to set the servo drives, refer to each relevant manual.

8-1 Registering NJ Variables

8-1-1 I/ F Variables for IAG and FB

I/ F variables of IAG and FB for MC Test Run are defined in the FB external variable as data type variable (structures). To allow the NA to access to the FB external variables, register the FB external variable in the global variable table of NJ.

The following table shows the NJ variables to register

Name	Data type	Comment
HMI_IAG_Axis	_sAXIS_REF	Monitor axis information for IAG
HMI_IAG_Axis_Status	IAG_Param_REF	Jog feed status for IAG
HMI_IAG_Connect_DeviceInfo	IAG_Device_Info	Connected device information for IAG
HMI_IAG_SeavoON_Execute	ARRAY[0..63] OF BOOL	Axis start processing for IAG

The data types of these variables are defined in FB, so you don't need to define them in [Data type] of the NJ Editor.

To access to these variables from NA, register the variable name to the global variable.

8-1-2 Variable Registration Procedure

Register the NJ variables before importing the FB library file.



Additional Information

A validation error will occur at this moment because the data types to be used for variables are not valid until the FB library file has been imported.

For example, a validation error for "IAG_Device_Info" will be cleared after importing the "Axis Information Acquire FB", and a validation error for "IAG_Param_REF" will be cleared after importing the "Manual Operation FB".

The registration procedure of the NJ variables is listed on the following pages.

1. Select "Programming" -> "Data" -> "Global Variables" from the multiview explorer of NJ project and double-click (or right-click -> Edit) to open the "Global Variable" table.

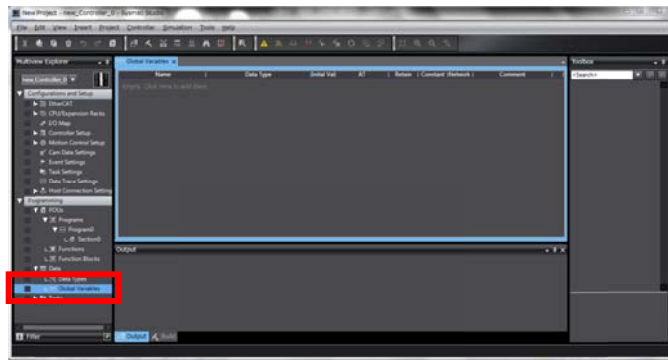

2. While the "Global Variables" table is active, right-click->"Create New" and register the NJ variables given in the table earlier in this section.

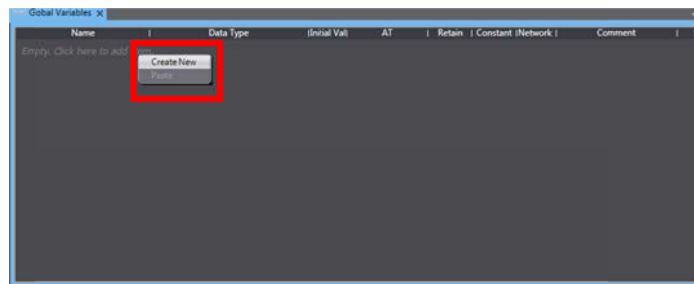

3. A validation error will occur but will be cleared after importing the FB library file in the next step.

Name	Data Type	Initial Val	AT	Retain	Constant (Network)	Comment
HMI_IAG_Axis	_SYS_REF			<input type="checkbox"/>	<input type="checkbox"/>	Do not put Monitor axis information for IAG
HMI_IAG_Axis_Status	IAG_Param_REF			<input type="checkbox"/>	<input type="checkbox"/>	Do not put Jog feed status for IAG
HMI_IAG_Connect_DeviceInfo	IAG_Device_Info			<input type="checkbox"/>	<input type="checkbox"/>	Do not put Connected device information for IAG
HMI_IAG_SeavoON_Execute	ARRAY(63) OF BOOL			<input type="checkbox"/>	<input type="checkbox"/>	Do not put Axis start processing for IAG

Additional Information

Using the excel file for variable declaration allows you to copy and paste variables. In step 2 above, copy the following data and paste them by selecting "Paste".

	D	E	F	G	H
1	HMI_IAG_Axis	FALSE	FALSE	Do not put	Monitor axis information for IAG
2	HMI_IAG_Axis_Status	FALSE	FALSE	Do not put	Jog feed status for IAG
3	HMI_IAG_Connect_DeviceInfo	FALSE	FALSE	Do not put	Connected device information for IAG
4	HMI_IAG_SeavoON_Execute	FALSE	FALSE	Do not put	Axis start processing for IAG

8-2 Importing FB Library File

·How to import the FB library files

1. Select "Project" ->"Library" ->"Show References" from the menu of NJ project.

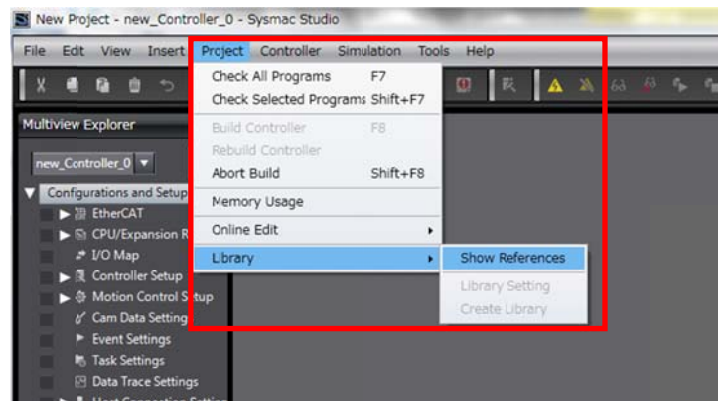

2. The Library Reference window opens. Click the + button.

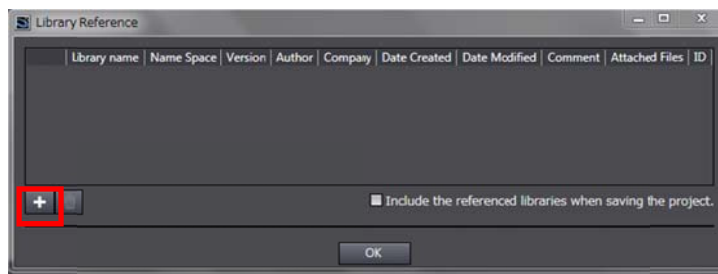

3. The dialog on the right opens. Select a FB library file to import. In this example, select "IAGCont_DeviceWindow_MCTestRun_V1_0.slr".

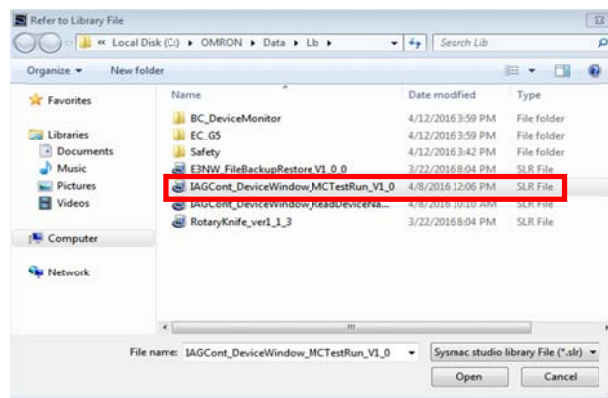

4. The FB library file has been imported. Use the same procedure and import "IAGCont_DeviceWindow_ReadDeviceName_V1_0.slr".

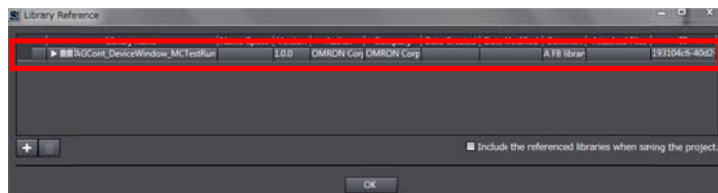

8-3 Adding FB to NJ Program

Place the specified FB to the NJ program and write the required programs.

· How to add FB to "Section0" (created by default when NJ project was created) with ladder.

1. Select "Programming" -> "POUs" -> "Program0" -> "Section0" from the menu of NJ project.

* A validation error will occur but will be cleared after writing the ladder.

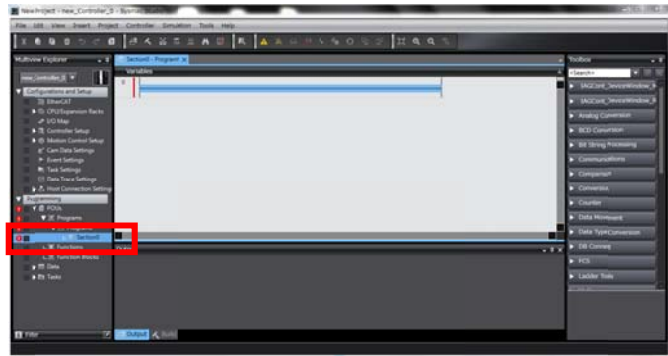

2. Select "IAGCont_DeviceWindow_MCTest Run_V1_0" from Toolbox.

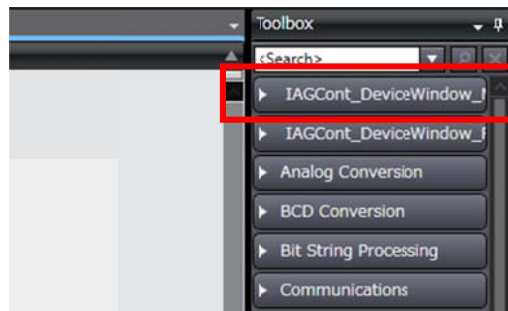

3. Drag "HMI_IAG_Axis_FB" from the drop-down list to the ladder editor.

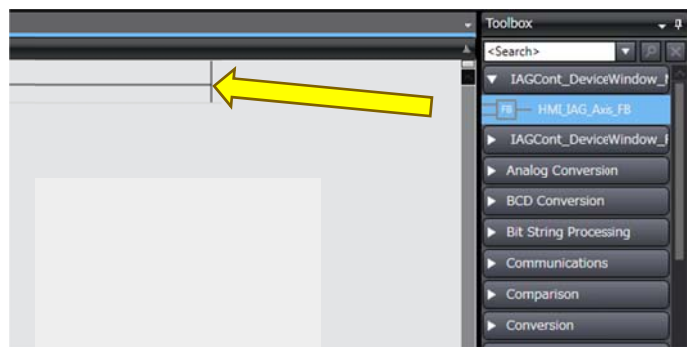

4. The FB has been added.



5. Write the programs as shown on the right.

In this example, instance "HMI_IAG_Axis_FB" is named as "HMI_IAG_Axis_FB_Ins".

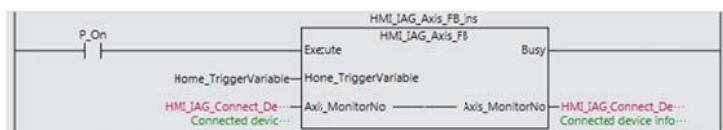

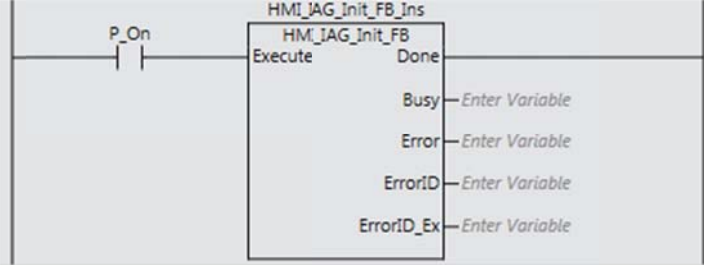
<p>In addition, set the home input signal of the environmental condition you used to “Home_TriggerVariable”.</p>	
<p>When using the ST structure, the above ladder diagram is written as shown on the right.</p>	<pre>HMI_IAG_Axis_FB_Ins (Execute := P_ON, Home_TriggerVariable := Home_TriggerVariable, Axis_MonitorNo := HMI_IAG_Connect_DeviceInfo.Axis_MonitorNo);</pre>
<p>6. Select “HMI_IAG_Init_FB” from “IAGCont_DeviceWindow_Read_DeviceName_V1_0.slr” and write the program as shown on the right.</p> <p>In this example, instance “HMI_IAG_Init_FB” is named as “HMI_IAG_Init_FB_Ins”.</p>	
<p>When using the ST structure, the above ladder diagram is written as shown on the right.</p>	<pre>HMI_IAG_Init_FB_Ins(Execute := P_ON);</pre>

8-4 Adding Axis Start Variables

8-4-1 Axis Start Variables and “MC_Power” Instruction

To start axes from the NA (IAG), add an input condition of the axis start variables for this IAG to the input of “MC_Power” instruction.

Since more than one “MC_Power” instruction cannot be placed to an axis, add the OR circuit of “HMI_IAG_SeavoON_Execute[*]”, which is a start trigger from this IAG, to the input circuit of “MC_Power” instruction located in the entire control program.

Since the “MC_Power” instruction exists for each axis, combine “HMI_IAG_SeavoON_Execute[X]” with “MC_Power” instruction for X-axis to add.

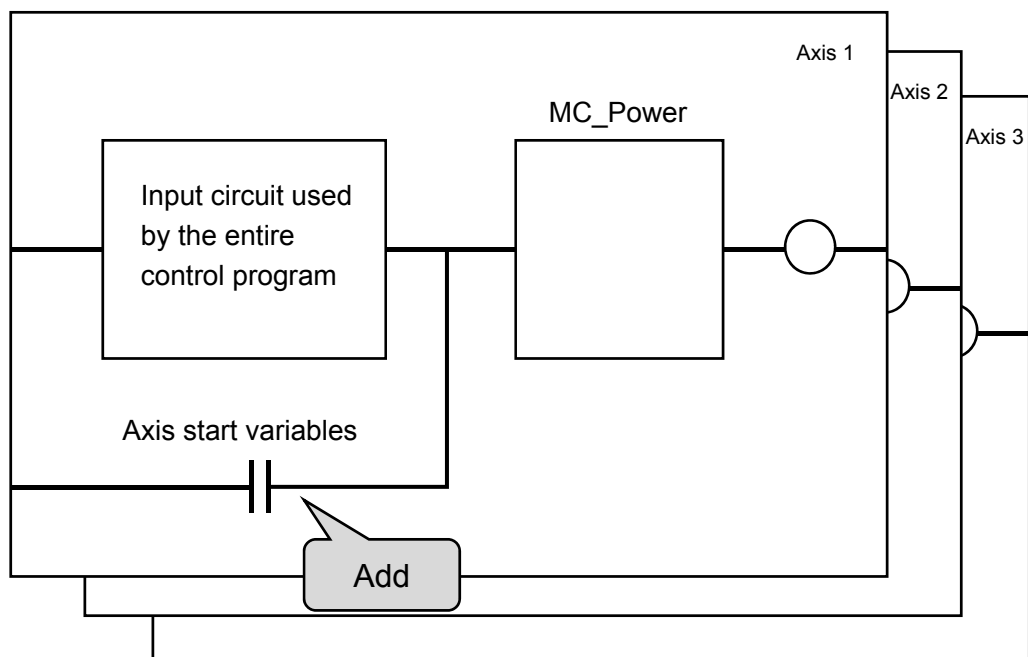

8-4-2 Design Procedure of Axis Start Circuit

· How to design the axis start circuits when using this IAG

1. Double-click (or right-click -> Edit) the program that uses the MC_Power instruction from the multiview explorer of NJ project to open the ladder editor. (In this example, "Programming" -> "POUs" -> "Common" -> "Common")

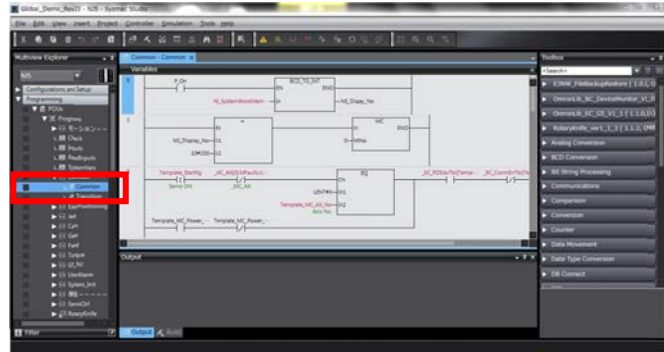

2. Make sure that each axis has been started using "MC_Power" instruction. (In this example, lines 7 and 8)

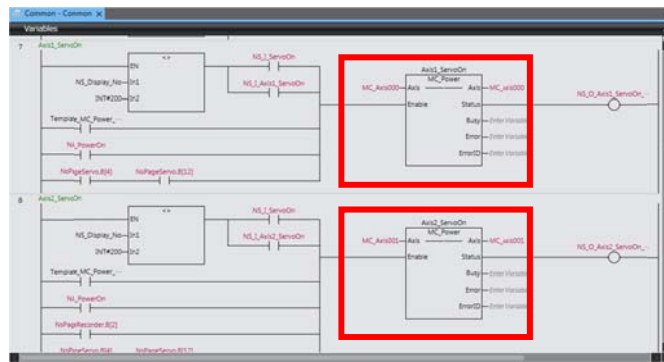

3. Drag the area from the left end of the line to the area you want to make connection.

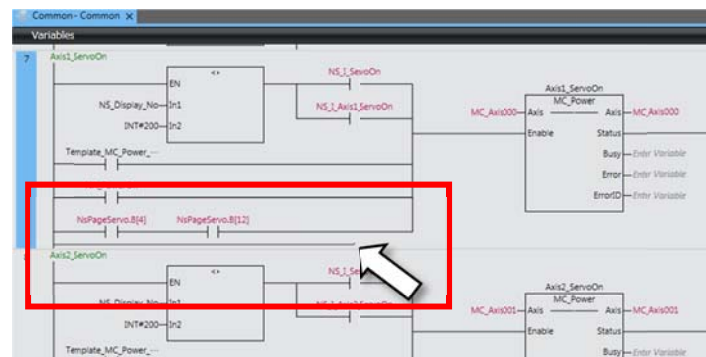

4. A prompt asking you for the object type to add is displayed. Select "N.O. Input (C)".

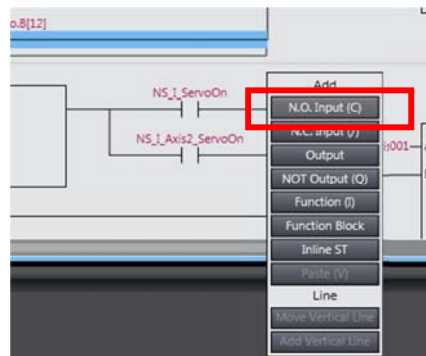

5. After adding the contact, set the added "HMI_IAG_ServoON_Execute" NJ variable there.
For axis 0, set "HMI_IAG_ServoON_Execute[0]".
For axis 1, set "HMI_IAG_ServoON_Execute[1]".



8-5 Registering and Mapping NA Variables

8-5-1 Mapping I/F Variable to NA

Add the data type variable used for IAG to the global variable list of NA. Use the usual variable mapping procedure for this registration.

The following table shows the NJ variables to map to the NA.

Name	Data type	Update rate	Comment
HMI_IAG_Axis	sAXIS_REF	100 ms	-
HMI_IAG_Axis_Status	IAG_Param_REF	100 ms	-
HMI_IAG_Connect_DeviceInfo	IAG_Device_Info	500 ms	-

8-5-2 Variable Mapping Procedure

Since the NJ variables have been registered to the NJ global variable in Step 8-1, use the usual procedure for mapping.

· How to map the NA variables

1. Select "Configurations and Setup" -> "Variable Mapping" from the multiview explorer of NA project and double-click (or right-click -> Edit) to open the "Variable Mapping" table.



2. Select the user variables for the Controller in the "Variable Mapping" table to display the NJ global variables.

Position	Port	Data Type	Variable	Variable-Comment
192.168.	NIS			
	System Variables			
	User Variables			
	HMI_IAG_Axis	sAXIS_REF		
	HMI_IAG_Axis_Status	IAG_Param_REF		
	HMI_IAG_Connect_DeviceInfo	IAG_Device_Info		
	HMI_IAG_SeavoON_Execut	ARRAY[0..63] OF BOOL		

3. Enter the NA variable names in the "Variable" column. (In this example, the NJ variable names are used for the NA variable names)

Position	Port	Data Type	Variable	Variable-Comment
192.168.	NIS			
	System Variables			
	User Variables			
	HMI_IAG_Axis	sAXIS_REF	HMI_IAG_Axis	
	HMI_IAG_Axis_Status	IAG_Param_REF	HMI_IAG_Axis_Status	
	HMI_IAG_Connect_DeviceInfo	IAG_Device_Info	HMI_IAG_Connect	
	HMI_IAG_SeavoON_Execut	ARRAY[0..63] OF BOOL		

4. Select "HMI" -> "Data" -> "Global Variables" from the multiview explorer and double-click (or right-click -> Edit) to open the "Global Variables" table.

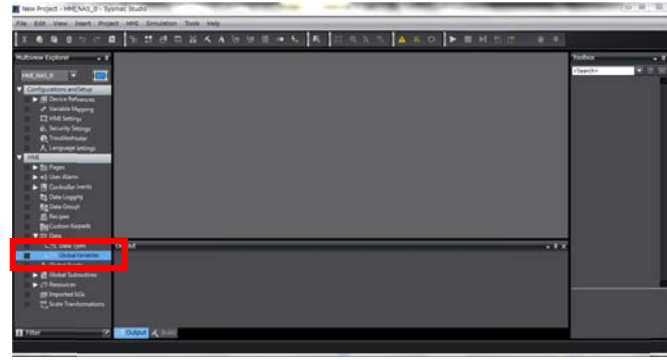

5. Make sure that the NA variables are set as you entered in step 3. Set the update rates given in the table earlier in this section.

Name	Data Type	Initial Value	AT	Retain	Constant	Update Rate	Scaling	Comment
HMI_JAG_Axis	NUS_AXIS_REF		NUS_HMI_J	<input type="checkbox"/>	<input type="checkbox"/>	100 Milliseconds	none	
HMI_JAG_Axis_Status	NUSJAG_Param_REF		NUS_HMI_J	<input type="checkbox"/>	<input type="checkbox"/>	100 Milliseconds	none	
HMI_JAG_Connect_Dev	NUSJAG_Device_J		NUS_HMI_J	<input type="checkbox"/>	<input type="checkbox"/>	500 Milliseconds	none	

The dropdown menu for the 'Update Rate' column is open, showing the following options: None, 100 Milliseconds, 500 Milliseconds, 1 Second, 2 Seconds, 5 Seconds, 10 Seconds, 30 Seconds, 1 Minute, 5 Minutes, 10 Minutes, 30 Minutes, 1 hour.

8-6 Importing IAG File

· How to import the IAG file to the HMI project

1. Select "Project" -> "IAG Collection Manager" from the menu of NA project.

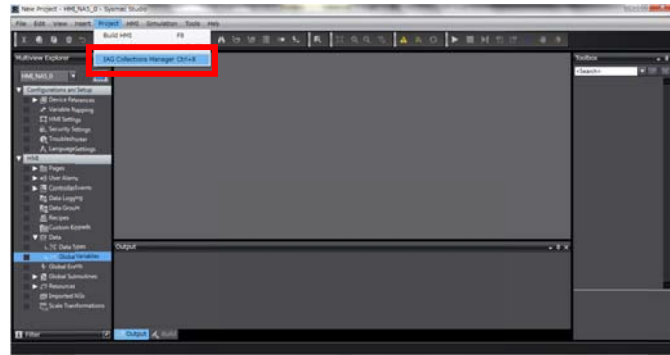

2. The IAG Collection Manager window is displayed. Click the  button.

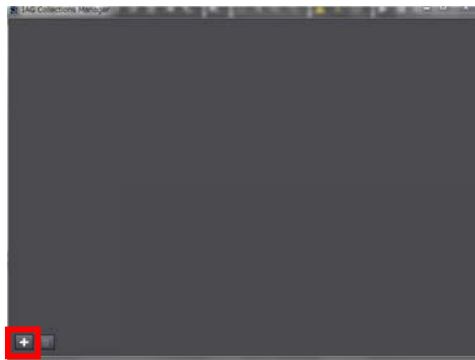

3. The dialog on the right opens. Select "DeviceWindowIAG_114A_E_MCTestRun_Popup.iag".

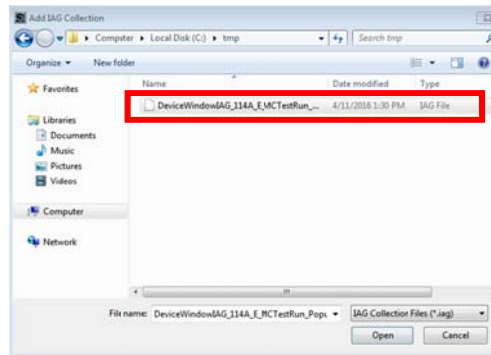

4. The IAG has been imported. Select the "Show in Toolbox" checkbox on the top right corner and close the dialog. (The IAG object can be enabled on the HMI page by selecting this checkbox).

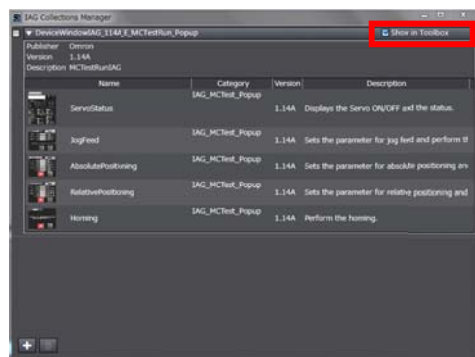

8-7 Placing IAG Object on NA Screen

·How to use the imported IAG objects on the HMI screen

1. Select "HMI" ->"Pages" from the multiview explorer of NA project and select the page, in which you want to place the IAG, and double-click(or right-click -> Edit) to open the page editor.

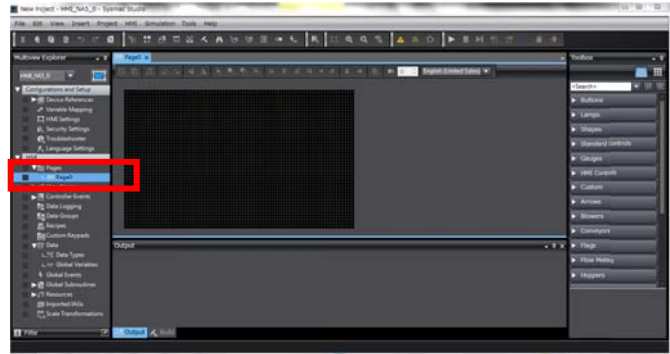

2. Select "IAG_MCTest_Popup" that was added in Toolbox.

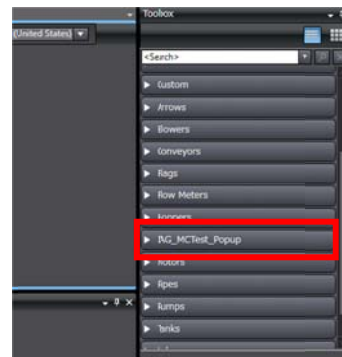

3. The five IAG objects are expanded. Place them to the page editor in the same way as you place usual objects.

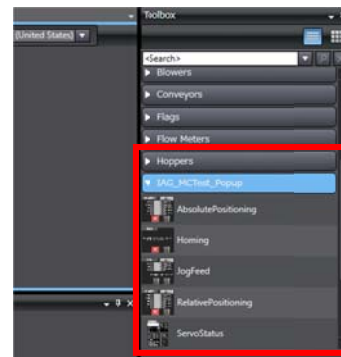

4. The IAG object has been placed. (In this example, ServoStatus is placed)

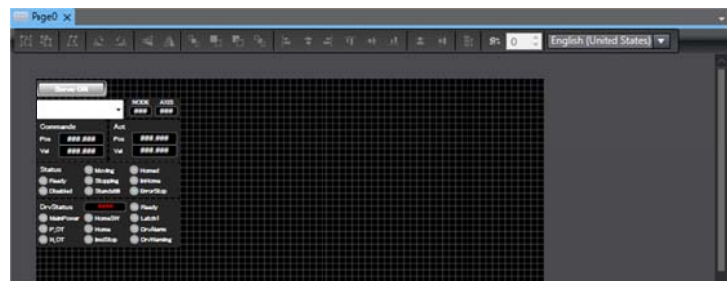

5. To use the IAG objects, set I/O variable in Properties of IAG objects.
Register each variable in Behaviour (In/Out) of Properties by following “3-2 Outline of System Configuration”.

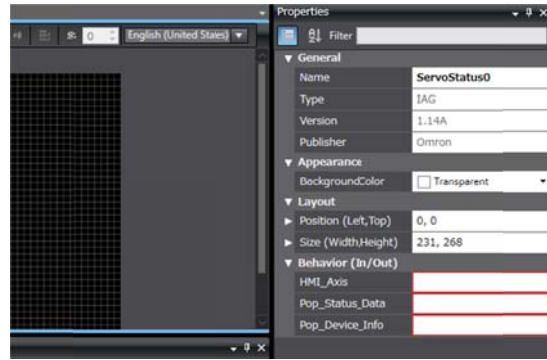

8-8 Adding Subroutine/ Event and Action to Page

You need to write the subroutines and Event and Action on the NA page in the following cases.

IAG	Required/ Not required	Extra work
Axis status monitor IAG	Required	Event and Action Subroutine
Manual operation IAG	Required when one manual operation IAG is positioned on the page.	Event and Action
Manual operation IAG	Required when multiple manual operation IAGs are positioned on the same page such as tab control object.	Event and Action Subroutine

The details and sample program are described in the following section.

8-8-1 Extra Work for Using Axis Status Monitor IAG

Axis status monitor IAG objects can acquire the name of the connected servos and displayed them in a drop-down list.

You need to define the execution timing of this function in Event and Action and call the subroutine inside IAG. Normally, this function is executed when the corresponding page is displayed.

·How to make the setting

1. Select "Pages" -> "Popup" from the multiview explorer of NA project and select the page, on which you placed IAG, and right-click->select "View Code Editor" to display the code editor of page subroutine.

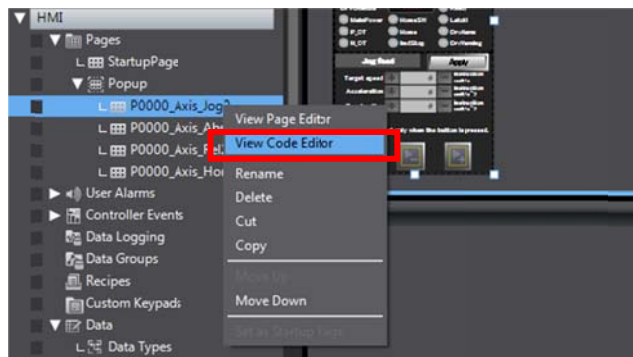

2. Write the sample program shown on the right to the page subroutine.
(In this example, the object name of axis status monitor IAG is "ServoStatus0")

```

2
3
4 Sub Call_IAG_Sub
5
6     ServoStatus0.List_ItemSet
7
8 End Sub
9

```

3. Select "Pages" -> "Popup" from the multiview explorer of NA project and select the page, on which you placed IAG, and right-click->select "Page Editor" to display the page editor.

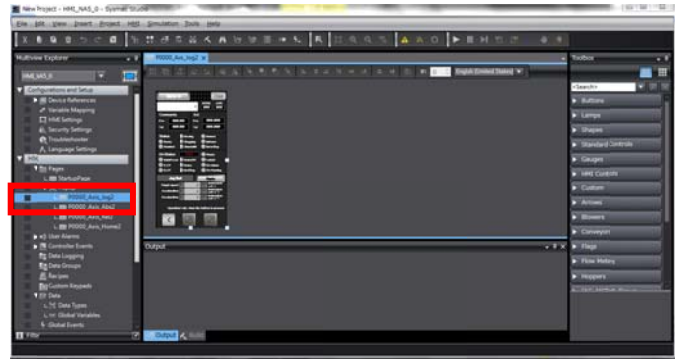

4. Select "Event and Action" from Toolbar.

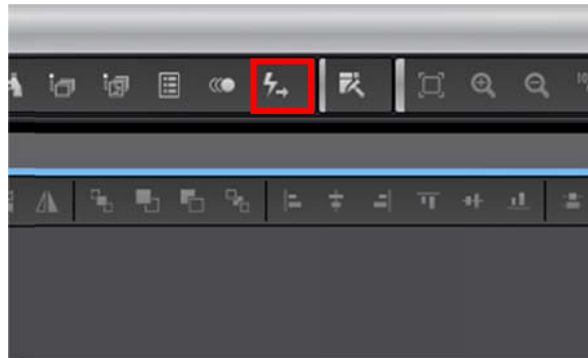

5. Select "PageDisplayed" for Events and "CallSubroutine" for Actions. Enter "Call_IAG_Sub" that you set in step 2 for Subroutine.

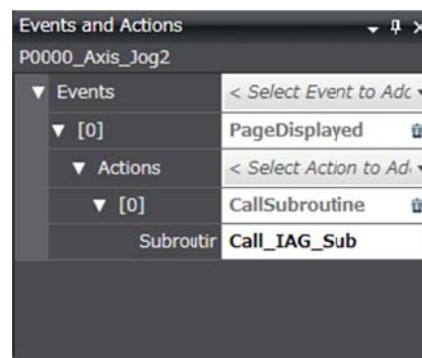

After performing the above procedure, you can run the subroutines that read the axis status inside the IAG.

8-8-2 Extra Work for Using Single Manual Operation IAG on Page

The manual operation FB that corresponds to the manual operation IAG is monitoring the function selection flag held by the manual operation IAG, and switches the MC Test Run function to be executed.

The following table shows the correspondence between the manual operation IAG and the function selection flags.

Manual operation IAG	Function selection flag
Jog Feed IAG	HMI_IAG_Axis_Status.Function_Flg = 0
Absolute Positioning IAG	HMI_IAG_Axis_Status.Function_Flg = 1
Relative Positioning IAG	HMI_IAG_Axis_Status.Function_Flg = 2
Homing IAG	HMI_IAG_Axis_Status.Function_Flg = 3

To execute the function that corresponds to the manual operation IAG displayed on the NA, select the function selection flag in Events when the page, on which the manual operation IAG is placed, is displayed (PageDisplayed).

·How to make the setting.

1. Select "Pages" -> "Popup" from the multiview explorer of NA project and select the page, on which you placed IAG, and right-click->select "Page Editor" to display the page editor.

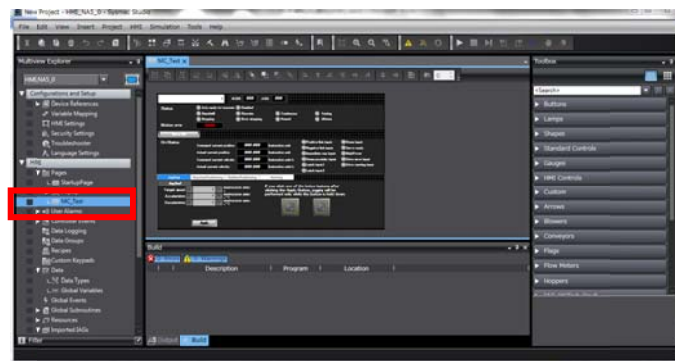

2. Select "Event and Action" from Toolbar.

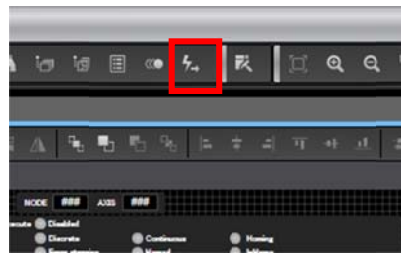

3. Select "PageDisplayed" for Events and select "SetVariable" for Actions. Enter "HMI_IAG_Axis_Status.Function_Flg" for Variable and enter the number corresponding to the displayed IAG for Value.

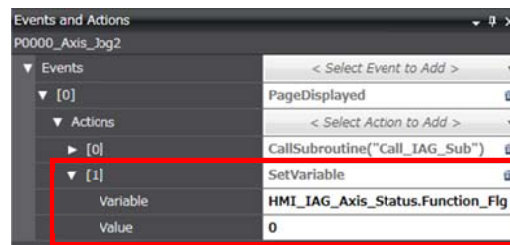

After performing the above procedure, you can run the manual operation IAG.



Additional Information

You don't need to perform the above procedure when multiple manual IAGs are placed on the same page.

8-8-3 Extra Work for Using Multiple Manual Operation IAGs on Page with Tab Control

Placing multiple manual operation IAGs such as tab control objects on the same page results in unexpected operations due to the conflict occurred in the function selection flag.

To avoid this, set the function selection flag for “Variable” in Properties of tab control object so that the multiple manual operation IAGs can be successfully operated on the same page.

· The setting procedure is given below

- When placing IAG on tab page in the order of function selection flag

1. Select “Pages” -> “Popup” on which you placed IAG and double-click (or right-click->”the page editor”) from the multiview explorer of NA project to display the page editor.

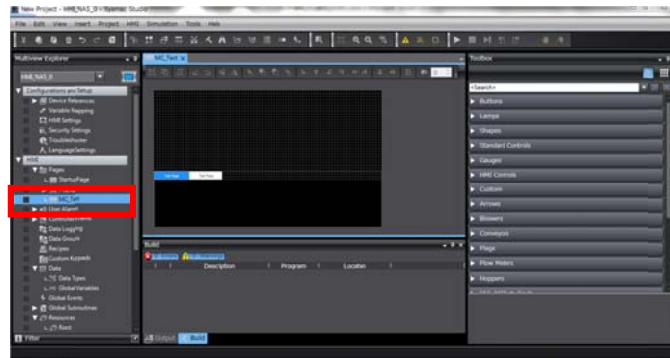

2. Select the tab control object you want to place IAG and display properties from Toolbar.

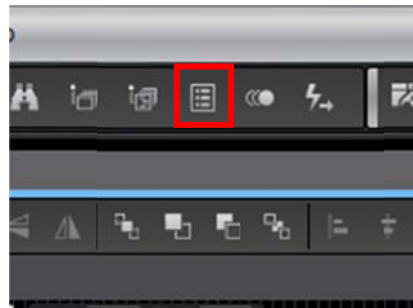

3. Set “HMI_IAG_Axis_Status.Function_Flg” for the “Variable” in Properties.

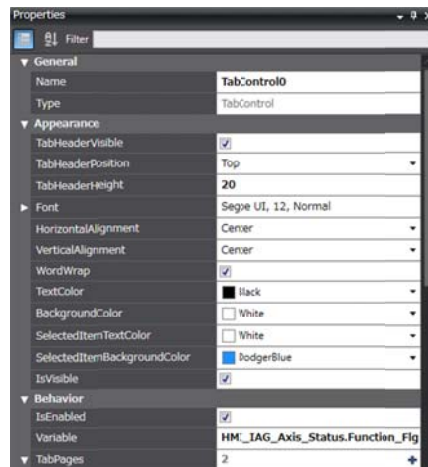

4. Place the IAG on each tab page so that the index of tab page corresponds to the function selection flag.
(Example: TabPage0 = JogFeed IAG)

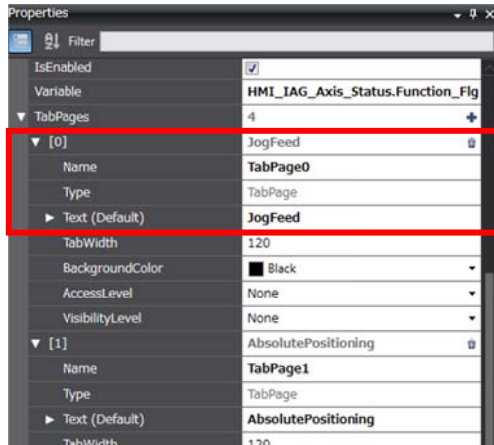

Additional Information

You don't need to perform the above procedure when single IAG is placed on the same page.

- When placing any IAG manual operation on any tab page

By calling up the subroutine that switches the function selection flags from “SelectionChanged” event of the tab control object, you can place any manual operation IAG and operate it properly on any tab page.

To display the tab page correctly when changing the corresponding page for the first time or after switching the function selection flag by the Controller, you also need to call up the same subroutine in the “PageDisplayed” event,.

- How to place the “absolute positioning IAG” and “homing IAG” only on the tab page.

1. Right-click the page, on which you placed IAG, and select “View Code Editor” from the multiview explorer of NA project to display the code editor of page subroutine.

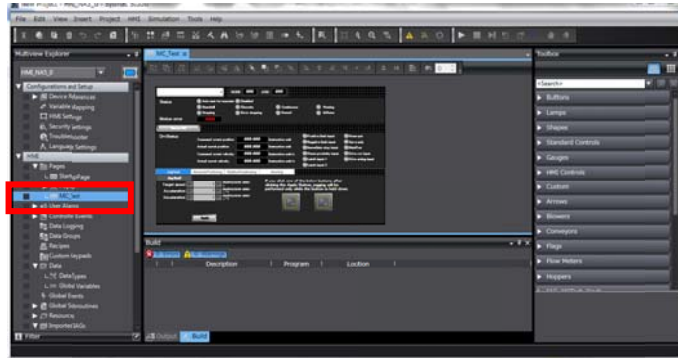

2. Write the programs as shown on the right to the page subroutine.

*In this example, variable is “PageChange”. In actual operation, use the variable that you set for “TabControl” variables in Properties.

```

11 Sub TabPageChange
12   Select PageChange
13     Case 0
14       HMI_IAG_Axis_Status.Function_Flg = 1 'Absolute Positioning
15     Case 1
16       HMI_IAG_Axis_Status.Function_Flg = 3 'Homing
17   End Select
18 End Sub

```

3. Select the tab control object, in which you placed IAG, and select “Event and Action” from Toolbar.

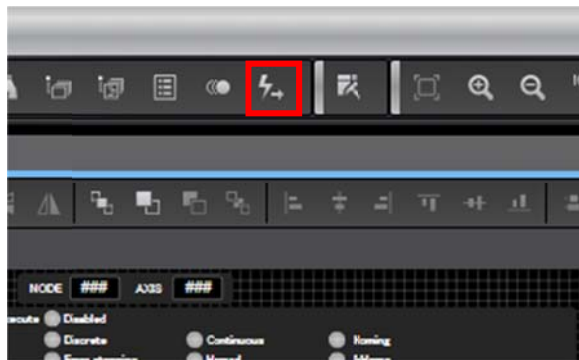

4. Select “SelectionChanged” for Events and set the subroutine name of “CallSubroutine” action to “TabPageChange” that you implemented in step 2.

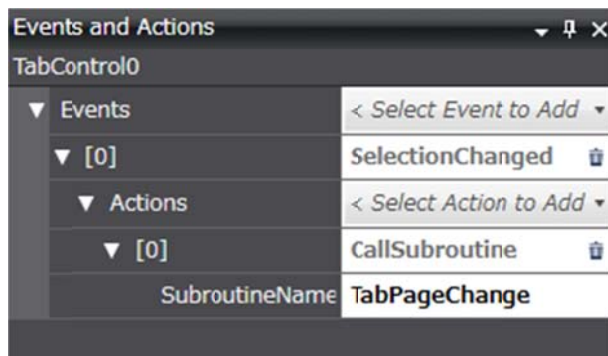

5. Select the page, on which you placed IAG, and select "Event and Action" from Toolbar.

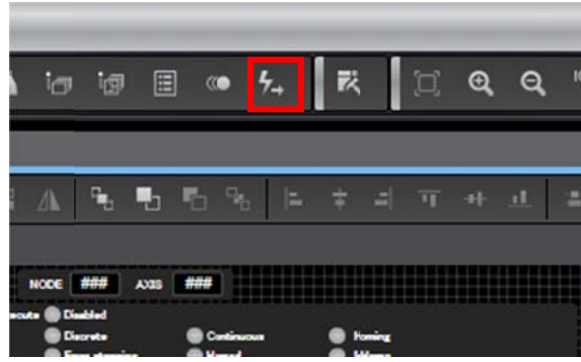

6. Select "PageDisplayed" for Events and set the subroutine name of "CallSubroutine" action to "TabPageChange" that you implemented in step 2.

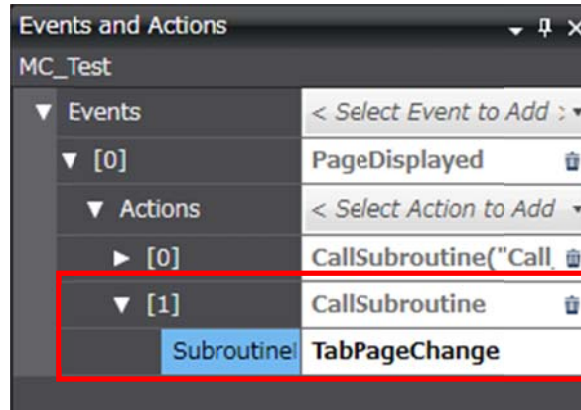

Revision History

Revision code	Date	Revised content
01	June, 2016	Original production

Note: Do not use this document to operate the Unit.

OMRON Corporation Industrial Automation Company

Tokyo, JAPAN

Contact: www.ia.omron.com

Regional Headquarters

OMRON EUROPE B.V.

Wegalaan 67-69, 2132 JD Hoofddorp
The Netherlands
Tel: (31)2356-81-300/Fax: (31)2356-81-388

OMRON ELECTRONICS LLC

2895 Greenspoint Parkway, Suite 200
Hoffman Estates, IL 60169 U.S.A
Tel: (1) 847-843-7900/Fax: (1) 847-843-7787

OMRON ASIA PACIFIC PTE. LTD.

No. 438A Alexandra Road # 05-05/08 (Lobby 2),
Alexandra Technopark,
Singapore 119967
Tel: (65) 6835-3011/Fax: (65) 6835-2711

OMRON (CHINA) CO., LTD.

Room 2211, Bank of China Tower,
200 Yin Cheng Zhong Road,
PuDong New Area, Shanghai, 200120, China
Tel: (86) 21-5037-2222/Fax: (86) 21-5037-2200

Authorized Distributor:

© OMRON Corporation 2016 All Rights Reserved.
In the interest of product improvement,
specifications are subject to change without notice.

Cat. No. V436-E1-01

0616 (0616)