

eCobra 600, 800 and 800 Inverted ePLC Robots

Quick Setup Guide



I594-E-01

Copyright Notice

The information contained herein is the property of Omron Adept Technologies, Inc., and shall not be reproduced in whole or in part without prior written approval of Omron Adept Technologies, Inc. The information herein is subject to change without notice and should not be construed as a commitment by Omron Adept Technologies, Inc. This manual is periodically reviewed and revised.

Omron Adept Technologies, Inc., assumes no responsibility for any errors or omissions in this document. Critical evaluation of this manual by the user is welcomed. Your comments assist us in preparation of future documentation. Please email your comments to: tech-pubs@adept.com.

Copyright© 2013, 2016 by Omron Adept Technologies, Inc. All rights reserved.

Any trademarks from other companies used in this publication are the property of those respective companies.

Printed in the United States of America

Chapter 1: Cobra ePLC Robot Quick Setup

1.1 Introduction

Process Overview

This Quick Setup Guide steps you through the installation and start-up of your Cobra ePLC robot. The major steps are:

- **Preparation**, including workcell layout and safety
- **Hardware Installation**, including mounting the robot and system cable connections
- **System Start-Up**, including system configuration and turning on the robot

NOTE: This guide does not apply to robot systems that include a SmartController motion controller. Refer to the eCobra robot user's guide for those systems.

During the installation and start-up process, refer also to your PLC user's guide and the eCobra user's guide, available on the support disk, for more information.

Resources on the Support Disk

- This guide
- The *eCobra Robot User's Guide*

Resources on Omron Web Sites

On the Omron Industrial Automation web site:

ia.omron.com

- The *ePLC Connect 3 Software User's Guide*
- EtherNet/IP Connection Guide (P649-E1-01)
This covers ePLC for the Omron NJ controller with Omron Adept Robots.
- EtherNet/IP Connection Guide (P650-E1-01)
This covers ePLCIO for the Omron NJ controller with Omron Adept robots.

On the Omron Adept web site:

adept.com

- Legacy systems communication structure pdfs
- Legacy systems code examples

1.2 Safety



WARNING: It is strictly prohibited to install or operate our robot without adequate safeguards according to applicable local and national standards. See the following figure for a simple workcell layout.

You must read the Robot Safety Guide and the Robot Installation and Operation chapters in the robot user's guide for information on safe operation of your robot system.

Refer to Installing User-Supplied Safety Equipment in the System Installation chapter of the robot user's guide, which provides details on connecting a user-designed E-Stop system to the XUSR connector on the robot.

1.3 Workcell Layout

The following figure shows a simple workcell layout with a user-supplied safety barrier and E-Stops provided by the Front Panel and optional T20 pendant.

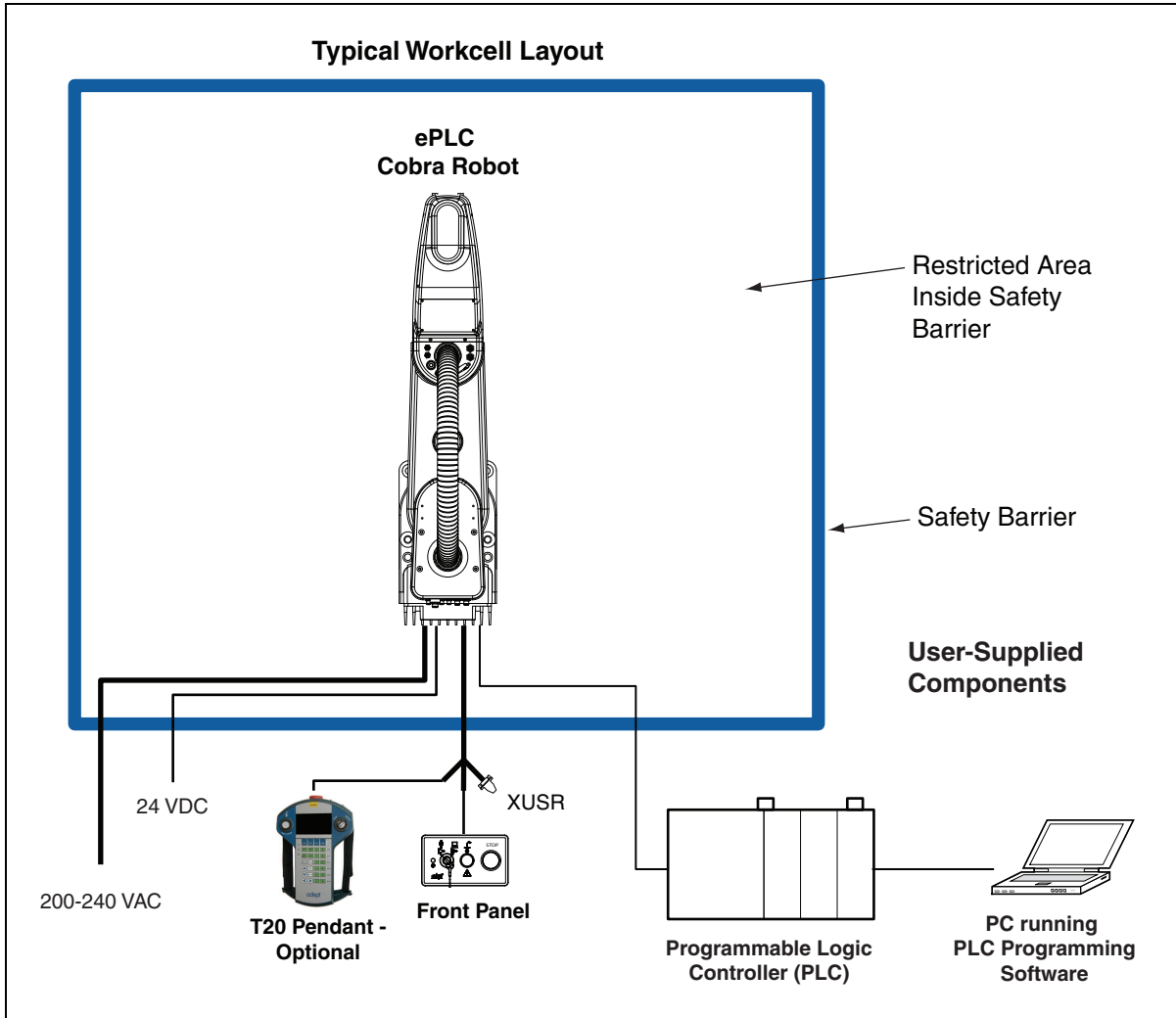

Figure 1-1. Typical Workcell Layout

1.4 Installing the Robot

NOTE: Do not move the robot's outer arm from the shipping position, as shown.

Support the robot by the eyebolt on the top of the inner link before removing the shipping bolts from the pallet. This will prevent the robot from tipping over. See the following figure.

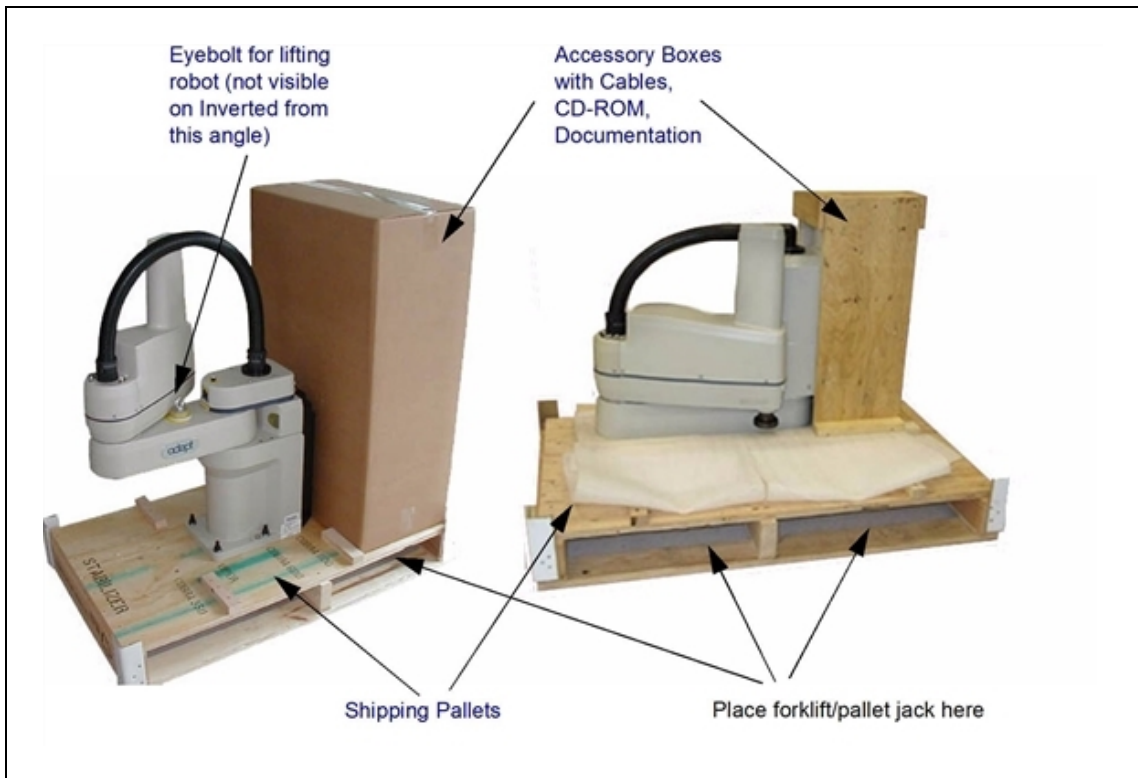

Figure 1-2. Cobra ePLC600, ePLC800 Inverted Robots on Pallets

Mounting the Robot

Mount the robot to a rigid surface that will prevent vibration and flexing during operation. We recommend a 25 mm (1 in.) thick steel plate, mounted to a rigid steel tube frame. See the following figures for the mounting hole dimensions.

1.4 Installing the Robot

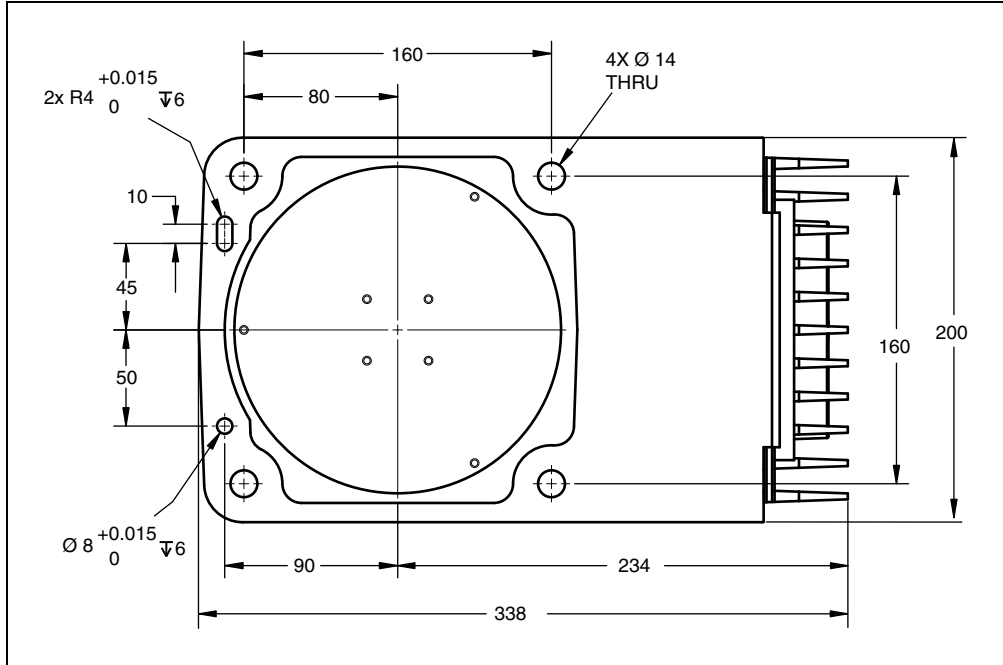

Figure 1-3. Mounting Hole Dimensions, Upright Robots

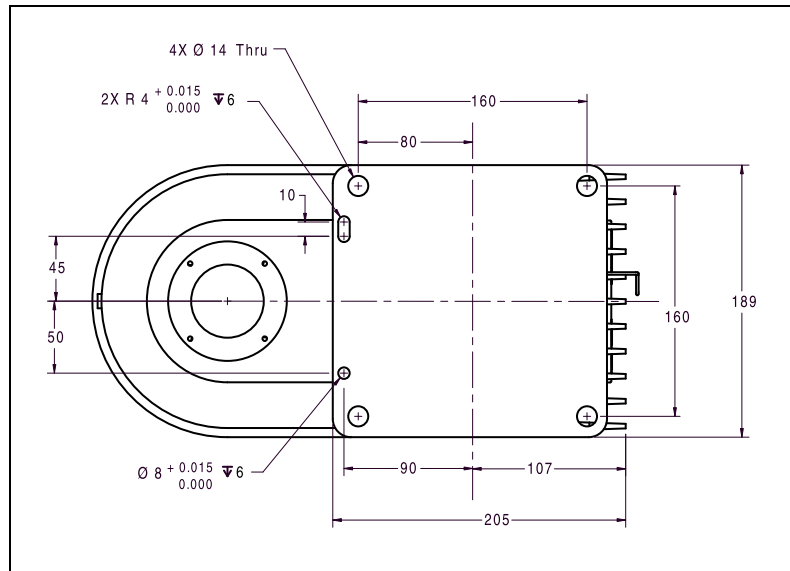

Figure 1-4. Mounting Hole Dimensions, Inverted Robot

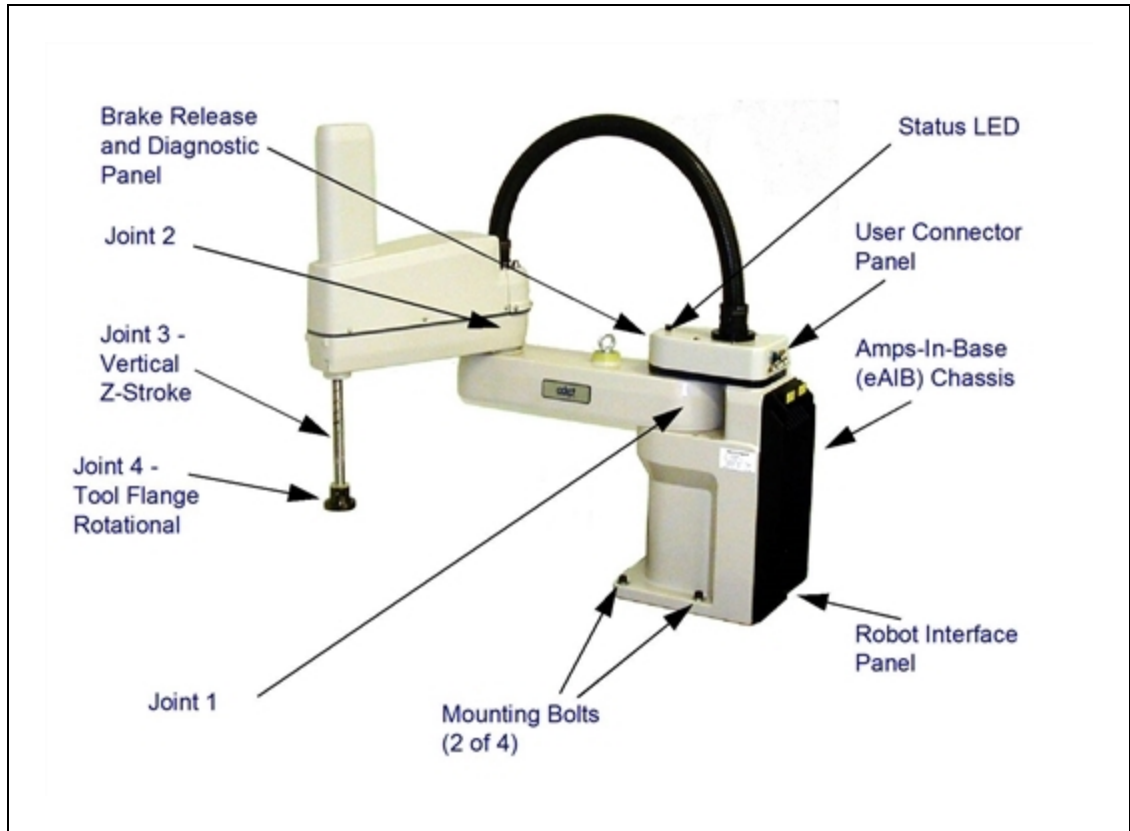

Figure 1-5. Cobra ePLC Components, ePLC800 Robot Shown

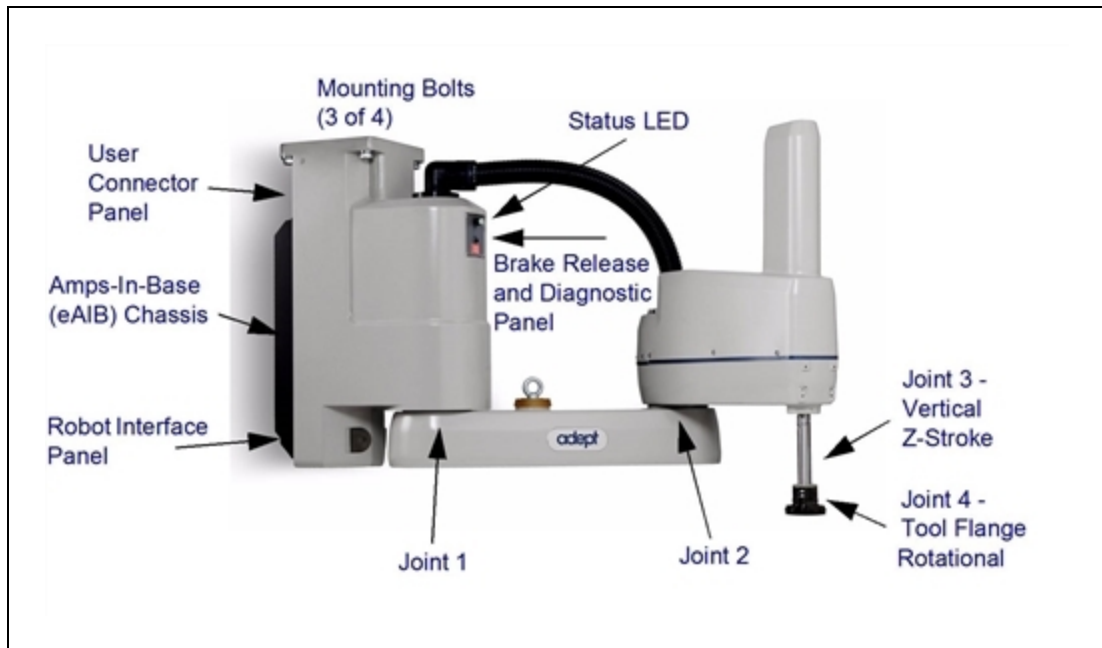

Figure 1-6. Cobra ePLC Components, ePLC800 Inverted Robot

1.5 System Cable Connections

Open the Accessory box and locate the eAIB XSYSTEM cable. Connect the cables and peripherals as shown in the following figure. Parts and steps are covered in the following two tables. Refer to the System Installation chapter in your Cobra user's guide for AC specifications and wiring instructions.

Part	Cable and Parts List	Part #	Part of:	Notes
A	eAIB XSYSTEM Cable Assembly	13323-000		standard, eAIB
B	User E-Stop, Safety Gate	n/a	n/a	user-supplied
C	XUSR Jumper Plug	04736-000	13323-000	standard, eAIB
D	Front Panel	90356-10358		standard
E	Front Panel Cable	10356-10500	90356-10358	standard
F	Front Panel Jumper Plug	10053-000	13323-000	standard, eAIB
G	XMCP Jumper Plug	04737-000	13323-000	standard, eAIB
H	T20 Bypass Plug	10048-000	10055-000	standard, T20
J	T20 Adapter Cable	10051-003	10055-000	standard, T20
K	T20 Pendant (option)	10055-000		option
L	AC Power Cable (option)	04118-000	90565-010	user-supplied
M	24 VDC Power Cable (option)	04120-000	90565-010	user-supplied
N	24 VDC, 6 A Power Supply (option)	04536-000	90565-010	user-supplied
P	Ethernet Cable - PC -> PLC (Only while programming PLC)	n/a	n/a	user-supplied
Q	Ethernet Cable - PLC -> switch	n/a	n/a	user-supplied
R	Ethernet Cable - switch -> SmartVision MX	n/a	n/a	user-supplied
S	Ethernet switch, cable	n/a	n/a	user-supplied
T	Camera and cable	n/a	n/a	option

Power Requirements

The power requirements for the SmartVision EX and the Cobra robot are covered in their respective user guides. For 24 VDC, both can be powered by the same power supply.

NOTE: The resistance of all ground conductors must be $\leq 10 \Omega$.

Step	Connection	Part
1	Connect eAIB XSYSTEM cable to XSYSTEM on eAIB	A
2	Connect a user E-Stop or Muted Safety Gate to the eAIB XSYSTEM cable XUSR connector or	B
2a	verify XUSR jumper plug is installed in eAIB XSYSTEM cable XUSR connector.	C
3	Connect Front Panel cable to Front Panel and eAIB XSYSTEM cable XFP connector or	D, E
3a	if no Front Panel, install FP jumper on eAIB XSYSTEM cable XFP connector. See NOTE after table.	F
4	Connect T20 adapter cable to eAIB XSYSTEM cable XMCP connector or	J, K
4a	if no T20, install XMCP jumper or T20 Adapter Cable with T20 bypass plug.	G or H
5	Connect user-supplied ground to robot. See robot user's guide for location.	n/a
5a	Connect user-supplied ground to SmartVision MX, if used. See SmartVision MX user's guide for location.	n/a
6	Connect 200-240 VAC to AC Input on eAIB Interface Panel; secure with clamp.	L
7	Connect 24 VDC to DC Input on Interface Panel.	N, M
7a	Connect 24 VDC to SmartVision MX, if used.	N, M
8	Connect Ethernet cable from PC to PLC.	P
9	Connect Ethernet cable from PLC to switch.	S
9a	Connect Ethernet cable from switch to eAIB.	Q, S
9b	Connect Ethernet cable from SmartVision MX, if used, to switch.	R, S
10	Connect optional camera and cable to SmartVision MX, if used.	T

NOTE: A Front Panel ships with each Cobra ePLC system, but you can choose not to use it if you replace its functionality with equivalent circuits. That is beyond the scope of this guide.

NOTE: If you can use the robot's default IP address, then you can skip the ACE software installation completely.

Installing ACE Software

ACE is used to change the IP address of the robot and for troubleshooting. You install the ACE software onto your PC from the software disk.

NOTE: You will have to restart the PC after installing ACE software.

Setting the Robot IP Address

Configure the IP address of the Cobra ePLC robot using ACE software.

1. Connect the PC and the robot, either through a shared network or with an Ethernet cable between them.
2. Start the ACE software.
3. Click the Detect and Configure button, circled in the following figure.

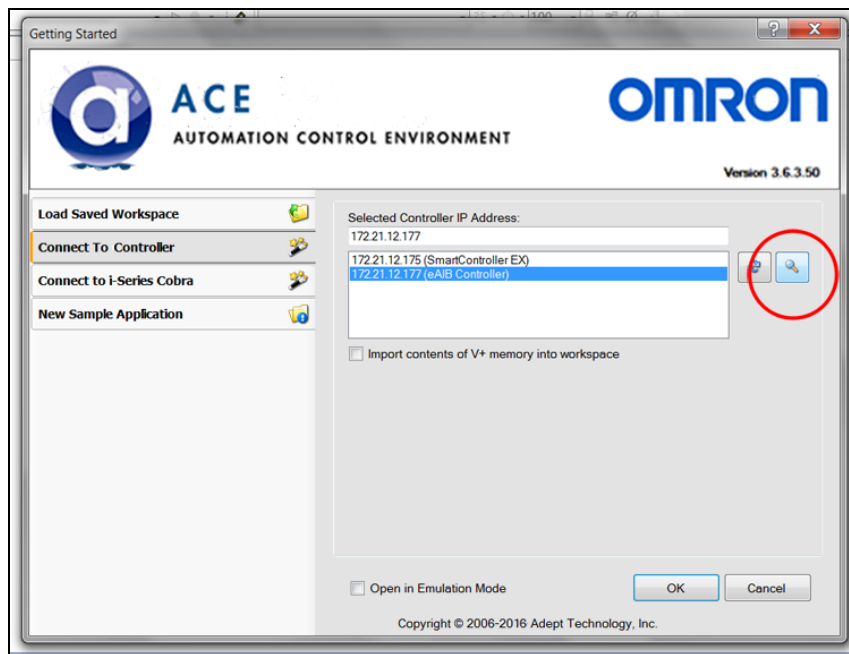

Figure 1-8. Detect and Configure Button

The IP address detection and configuration window will open. The ACE software will show the IP address of any controllers it detects. See the following figure.

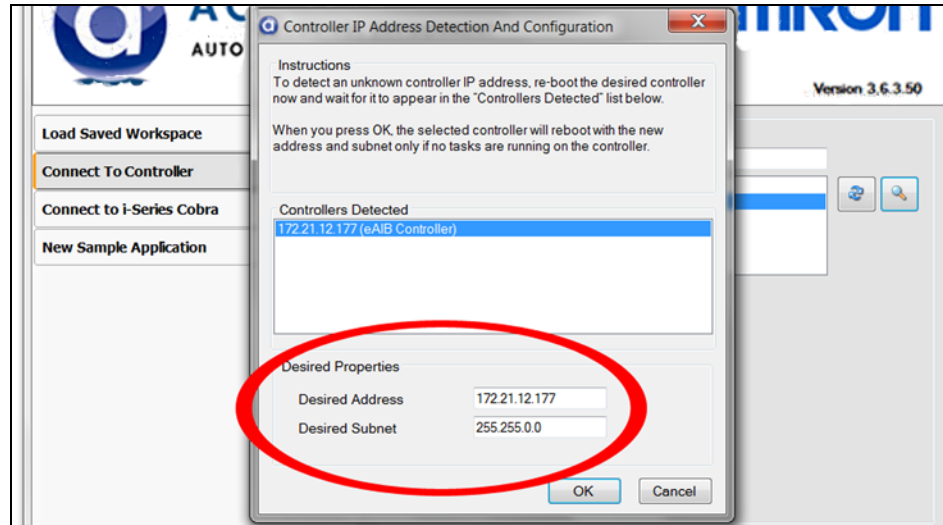

Figure 1-9. IP Addresses Detected

4. You can change the IP address and subnet mask in the Desired Address and Desired Subnet fields, if needed.
5. Click OK. The ACE software will ask you to wait for the controller to reboot.

Configuring the Omron PLC

Refer to the EtherNet/IP Connection Guide (P649-E1-01) for configuring the Omron PLC to work with Omron Adept robots. Refer to Resources on Omron Web Sites on page 3.

Using your PLC software, set the IP address for the PLC to connect to on the robot.

Enabling High Power

The details of enabling high power to the robot are covered in the EtherNet/IP Connection Guide (P649-E1-01).

Once high power is enabled, the Robot Status Panel displays ON, and the amber Robot Status LED is on.

1.7 Finding Additional Information

Installing Optional Equipment

For details on installing optional equipment, see the following topics in the Optional Equipment Installation chapter of the eCobra user's guide:

- Installing end-effectors
- Connecting user air and electrical lines to user connection panel
- Mounting external equipment on the robot
- Mounting the robot solenoid option kit

NOTE: For dimensions and specifications, see Technical Specifications in the eCobra user's guide.

System Operation

For details on system operation, see the following topics in the System Operation chapter of the eCobra user's guide:

- Robot Status LED Indicator
- Status panel fault codes
- Brake Release button (located above or in diagnostic panel). To move Joint 3 manually, press the Brake Release button.
- Connecting digital I/O on the XIO connector at the robot interface panel
- Connecting a user-designed E-Stop System

OMRON Corporation Industrial Automation Company
Kyoto, JAPAN
Contact: industrial.omron.eu

Regional Headquarters

OMRON EUROPE B.V.

Wegalaan 67-69, 2132 JD Hoofddorp
The Netherlands
Tel: (31)2356-81-300/Fax: (31)2356-81-388

OMRON ASIA PACIFIC PTE. LTD.

No. 438A Alexandra Road # 05-05/08 (Lobby 2),
Alexandra Technopark,
Singapore 119967
Tel: (65) 6835-3011/Fax: (65) 6835-2711

OMRON ELECTRONICS LLC

2895 Greenspoint Parkway, Suite 200 Hoffman Estates,
IL 60169 U.S.A.
Tel: (1) 847-843-7900/Fax: (1) 847-843-7787

OMRON ADEPT TECHNOLOGIES, INC.

4550 Norris Canyon Road, Suite 150, San Ramon, CA 94583 U.S.A.
Tel: (1) 925-245-3400/Fax: (1) 925-960-0590

OMRON (CHINA) CO., LTD.

Room 2211, Bank of China Tower, 200 Yin Cheng Zhong Road,
PuDong New Area, Shanghai, 200120, China
Tel: (86) 21-5037-2222/Fax: (86) 21-5037-2200

Authorized Distributor:

© OMRON Corporation 2016 All Rights Reserved.
In the interest of product improvement,
specifications are subject to change without notice.

Printed in USA

Cat. No. I594-E-01

0416