

**SIEMENS**



# SIMATIC

**S7-1500 / ET 200MP**

Digital input module F-DI 16x24VDC (6ES7526-1BH00-0AB0)

Manual

Translation of original operating instructions

Edition

01/2016

Answers for industry.

# SIEMENS

## SIMATIC

ET 200MP  
Digital input module  
F-DI 16x24VDC  
(6ES7526-1BH00-0AB0)

Manual

Preface

---

Documentation guide

1

Product overview

2

Connecting

3

Parameters/address space

4

Applications of the  
F-I/O module

5

Interrupts/diagnostic  
messages

6

Technical specifications

7

Response times

A



Open Source Software

B

## Legal information

### Warning notice system

This manual contains notices you have to observe in order to ensure your personal safety, as well as to prevent damage to property. The notices referring to your personal safety are highlighted in the manual by a safety alert symbol, notices referring only to property damage have no safety alert symbol. These notices shown below are graded according to the degree of danger.

 <b>DANGER</b>
indicates that death or severe personal injury <b>will</b> result if proper precautions are not taken.
 <b>WARNING</b>
indicates that death or severe personal injury <b>may</b> result if proper precautions are not taken.
 <b>CAUTION</b>
indicates that minor personal injury can result if proper precautions are not taken.
<b>NOTICE</b>
indicates that property damage can result if proper precautions are not taken.

If more than one degree of danger is present, the warning notice representing the highest degree of danger will be used. A notice warning of injury to persons with a safety alert symbol may also include a warning relating to property damage.

### Qualified Personnel

The product/system described in this documentation may be operated only by **personnel qualified** for the specific task in accordance with the relevant documentation, in particular its warning notices and safety instructions. Qualified personnel are those who, based on their training and experience, are capable of identifying risks and avoiding potential hazards when working with these products/systems.

### Proper use of Siemens products

Note the following:

 <b>WARNING</b>
Siemens products may only be used for the applications described in the catalog and in the relevant technical documentation. If products and components from other manufacturers are used, these must be recommended or approved by Siemens. Proper transport, storage, installation, assembly, commissioning, operation and maintenance are required to ensure that the products operate safely and without any problems. The permissible ambient conditions must be complied with. The information in the relevant documentation must be observed.

### Trademarks

All names identified by ® are registered trademarks of Siemens AG. The remaining trademarks in this publication may be trademarks whose use by third parties for their own purposes could violate the rights of the owner.

### Disclaimer of Liability

We have reviewed the contents of this publication to ensure consistency with the hardware and software described. Since variance cannot be precluded entirely, we cannot guarantee full consistency. However, the information in this publication is reviewed regularly and any necessary corrections are included in subsequent editions.

# Preface

## Purpose of the documentation

This manual supplements the system manual S7-1500 Automation System. You can find information on the functions that apply generally to the S7-1500 automation system and the ET 200MP distributed I/O system in the system manual S7-1500 Automation System (<http://support.automation.siemens.com/WW/view/en/59191792>).

The information provided in this manual and the system manual enables you to commission the S7-1500 automation system and ET 200MP distributed I/O system.

## Conventions

STEP 7: In this documentation, "STEP 7" is used as a synonym for all versions of the configuration and programming software "STEP 7 (TIA Portal)".

Please also observe the notes identified as follows:

---

### Note

A note includes important information on the product described in the documentation, on handling the product or on the part of the documentation to which particular attention should be paid.

---

---

## Important note for maintaining the operational safety of your system

---

### Note

The operators of systems with safety-related characteristics must adhere to specific operational safety requirements. The supplier is also obliged to comply with special product monitoring measures. Siemens informs system operators by means of personal notifications about product developments and properties which may be or become important issues in terms of operational safety.

You should subscribe to the corresponding notifications in order to obtain the latest information and to allow you to make any necessary modifications to your system.

Log in to Industry Online Support. Follow the links below and click on "Email on update" on the right-hand side in each case:

- SIMATIC S7-300/S7-300F  
(<https://support.industry.siemens.com/cs/products?pnid=13751&lc=en-WW>)
  - SIMATIC S7-400/S7-400H/S7-400F/FH  
(<https://support.industry.siemens.com/cs/products?pnid=13828&lc=en-WW>)
  - SIMATIC S7-1500/SIMATIC S7-1500F  
(<https://support.industry.siemens.com/cs/products?pnid=13716&lc=en-WW>)
  - SIMATIC S7-1200/SIMATIC S7-1200F  
(<https://support.industry.siemens.com/cs/products?pnid=13683&lc=en-WW>)
  - Distributed I/O (<https://support.industry.siemens.com/cs/products?pnid=14029&lc=en-WW>)
  - STEP 7 (TIA Portal)  
(<https://support.industry.siemens.com/cs/products?pnid=14340&lc=en-WW>)
- 

## Security information

Siemens provides products and solutions with industrial security functions that support the secure operation of plants, solutions, machines, equipment and/or networks. They are important components in a holistic industrial security concept. With this in mind, Siemens' products and solutions undergo continuous development. Siemens recommends strongly that you regularly check for product updates.

For the secure operation of Siemens products and solutions, it is necessary to take suitable preventive action (e.g. cell protection concept) and integrate each component into a holistic, state-of-the-art industrial security concept. Third-party products that may be in use should also be considered. You can find more information about industrial security on the Internet (<http://www.siemens.com/industrialsecurity>).

To stay informed about product updates as they occur, sign up for a product-specific newsletter. You can find more information on the Internet (<http://support.automation.siemens.com>).

## **Open Source Software**

Open-source software is used in the firmware of the product described. Open Source Software is provided free of charge. We are liable for the product described, including the open-source software contained in it, pursuant to the conditions applicable to the product. Siemens accepts no liability for the use of the open source software over and above the intended program sequence, or for any faults caused by modifications to the software.

For legal reasons, we are obliged to publish the original text of the license conditions and copyright notices. Please read the information relating to this in the appendix.

# Table of contents

	<b>Preface</b> .....	<b>4</b>
<b>1</b>	<b>Documentation guide</b> .....	<b>9</b>
1.1	Guide to documentation S7-1500 / ET 200MP .....	9
<b>2</b>	<b>Product overview</b> .....	<b>12</b>
2.1	Properties .....	12
<b>3</b>	<b>Connecting</b> .....	<b>15</b>
3.1	Block diagram .....	15
<b>4</b>	<b>Parameters/address space</b> .....	<b>17</b>
4.1	Parameters .....	17
4.2	Explanation of parameters .....	20
4.2.1	F-parameters .....	20
4.2.1.1	Behavior after channel fault .....	20
4.2.1.2	Reintegration after channel fault .....	20
4.2.2	Parameters of the sensor supply .....	21
4.2.2.1	Supplied channels .....	21
4.2.2.2	Short-circuit test activated .....	21
4.2.2.3	Time for short-circuit test .....	22
4.2.2.4	Startup time of sensors after short-circuit test .....	23
4.2.3	Parameters of the channel pairs .....	23
4.2.3.1	Sensor evaluation .....	23
4.2.3.2	Discrepancy behavior .....	24
4.2.3.3	Discrepancy time .....	25
4.2.3.4	Reintegration after discrepancy error .....	26
4.2.4	Parameters of the channels .....	26
4.2.4.1	Channel activated .....	26
4.2.4.2	Input delay .....	27
4.2.4.3	Channel failure acknowledge .....	28
4.2.4.4	Pulse extension .....	28
4.2.4.5	Chatter monitoring .....	28
4.2.4.6	Number of signal changes .....	29
4.2.4.7	Monitoring window .....	29
4.3	Address space .....	30
<b>5</b>	<b>Applications of the F-I/O module</b> .....	<b>32</b>
5.1	Applications of the F-DI 16x24VDC .....	32
5.2	Application 1: Safety mode SIL3/Cat.3/PLd .....	34
5.3	Application 2: Safety mode SIL3/Cat.3/PLe .....	37
5.4	Application 3: Safety mode SIL3/Cat.4/PLe .....	41
5.4.1	Application 3.1 (SIL3/Cat.4/PLe) .....	42
5.4.2	Use case 3.2 (SIL3/Cat.4/PLe) .....	44

<b>6</b>	<b>Interrupts/diagnostic messages</b> .....	<b>47</b>
6.1	Status and error displays .....	47
6.2	Interrupts .....	50
6.3	Diagnostic alarms.....	51
<b>7</b>	<b>Technical specifications</b> .....	<b>57</b>
<b>A</b>	<b>Response times</b> .....	<b>60</b>
<b>B</b>	<b>Open Source Software</b> .....	<b>62</b>



# Documentation guide

## 1.1 Guide to documentation S7-1500 / ET 200MP

The documentation for the SIMATIC S7-1500 automation system and the SIMATIC ET 200MP distributed I/O system is arranged into three areas. This arrangement enables you to access the specific content you require.

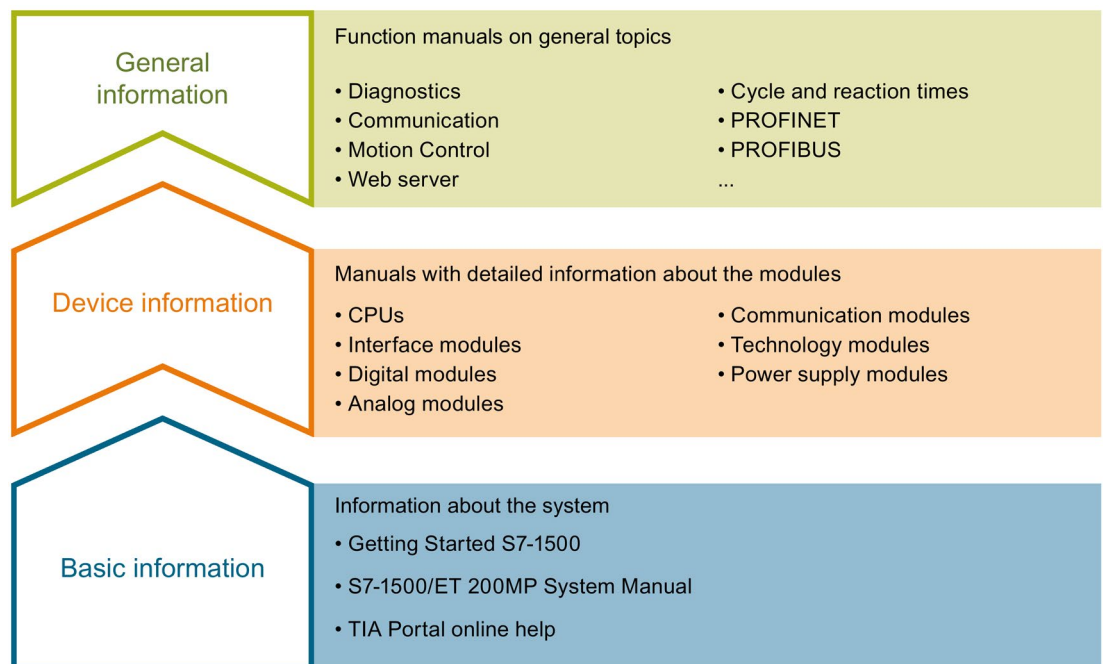

### Basic information

The System Manual and Getting Started describe in detail the configuration, installation, wiring and commissioning of the SIMATIC S7-1500 and ET 200MP systems. The STEP 7 online help supports you in the configuration and programming.

### Device information

Product manuals contain a compact description of the module-specific information, such as properties, wiring diagrams, characteristics and technical specifications.

### General information

The function manuals contain detailed descriptions on general topics regarding the SIMATIC S7-1500 and ET 200MP systems, e.g. diagnostics, communication, Motion Control, Web server.

You can download the documentation free of charge from the Internet (<http://www.automation.siemens.com/mcms/industrial-automation-systems-simatic/en/manual-overview/tech-doc-controllers/Pages/Default.aspx>).

Changes and supplements to the manuals are documented in a Product Information.

You can download the product information free of charge from the Internet.

## Manual Collection S7-1500/ET 200MP

The Manual Collection contains the complete documentation on the SIMATIC S7-1500 automation system and the ET 200MP distributed I/O system gathered together in one file.

You can find the Manual Collection on the Internet (<http://support.automation.siemens.com/WW/view/en/86140384>).

## "mySupport"

With "mySupport", your personal workspace, you make the best out of your Industry Online Support.

In "mySupport", you can save filters, favorites and tags, request CAx data and compile your personal library in the Documentation area. In addition, your data is already filled out in support requests and you can get an overview of your current requests at any time.

You must register once to use the full functionality of "mySupport".

You can find "mySupport" on the Internet.

## "mySupport" - Documentation

In the Documentation area in "mySupport" you can combine entire manuals or only parts of these to your own manual.

You can export the manual as PDF file or in a format that can be edited later.

You can find "mySupport" - Documentation on the Internet (<http://support.industry.siemens.com/My/ww/en/documentation>).

## "mySupport" - CAx data

In the CAx data area in "mySupport", you can access the current product data for your CAx or CAe system.

You configure your own download package with a few clicks.

In doing so you can select:

- Product images, 2D dimension drawings, 3D models, internal circuit diagrams, EPLAN macro files
- Manuals, characteristics, operating manuals, certificates
- Product master data

You can find "mySupport" - CAx data on the Internet (<http://support.industry.siemens.com/my/ww/en/CAxOnline>).

## Application examples

The application examples support you with various tools and examples for solving your automation tasks. Solutions are shown in interplay with multiple components in the system - separated from the focus on individual products.

You will find the application examples on the Internet (<https://support.industry.siemens.com/sc/ww/en/sc/2054>).

## TIA Selection Tool

With the TIA Selection Tool, you can select, configure and order devices for Totally Integrated Automation (TIA).

This tool is the successor of the SIMATIC Selection Tool and combines the known configurators for automation technology into one tool.

With the TIA Selection Tool, you can generate a complete order list from your product selection or product configuration.

You can find the TIA Selection Tool on the Internet

(<http://w3.siemens.com/mcms/topics/en/simatic/tia-selection-tool>).

## Product overview

### 2.1 Properties

#### Order number

6ES7526-1BH00-0AB0

#### View of the module

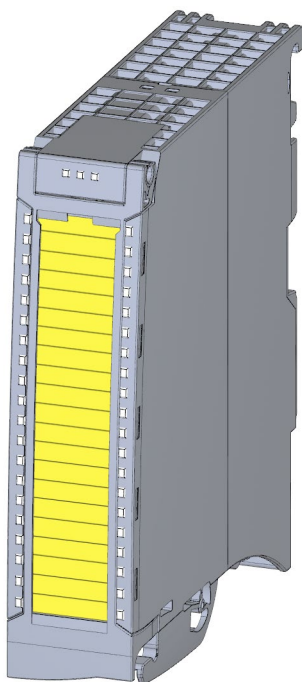

Image 2-1 View of the F-DI 16x24VDC module

## Properties

- Technical properties
  - Fail-safe digital module for use in the S7-1500 automation system and in the ET 200MP distributed I/O system.
  - PROFIsafe
  - PROFIsafe address type 2
  - Supports the RIOforFA-Safety profile (on S7-1500 F-CPU)
  - 16 inputs (SIL3/Category 3/PLd) or 8 inputs (SIL3/Category 4/PLe)
  - 4 outputs for sensor supply
  - Use of various interconnection types are possible (1oo1 & 1oo2)
  - Supply voltage L+
  - Sink input (P-reading)
  - Suitable for connection of 3/4-wire sensors according to IEC 61131:2007, type 1
  - Channel-specific assignable input delay 0.4 ms to 20 ms
  - Internal short-circuit-proof sensor supplies for each channel group
  - External sensor supply possible
  - Status display RUN (green LED)
  - Status display module diagnostics (red LED)
  - Status display channel status/channel diagnostics per input (green/red LED)
  - Status display supply voltage (green LED)
  - Diagnostics, e.g., short-circuit, channel-specific
  - Diagnostics, e.g., load voltage missing, module-specific
  - Channel-specific or module-wide passivation
- Supported functions
  - Firmware update
  - I&M identification data

### WARNING

The fail-safe performance characteristics in the technical specifications apply for a mission time of 20 years and a repair time of 100 hours. If a repair within 100 hours is not possible, switch off the supply voltage of the affected module before 100 hours expires.

Follow the repair procedure described in section Diagnostic alarms (Page 51).

### Accessories

The following accessories are supplied with the module and can also be ordered as spare part:

- Labeling strips
- U-connector
- Universal front cover
- Electronic coding element

### Additional components

The following component is to be ordered separately:

- Front connector incl. potential bridges and cable ties

You can find additional information on accessories in the S7-1500/ET 200MP (<http://support.automation.siemens.com/WW/view/en/59191792>) system manual.

# Connecting

## 3.1 Block diagram

This section includes the block diagram with the general pin assignment of the F-module.

For information on parameter assignment of the F-module, refer to "Parameters/address space (Page 17)".

Information on different connection options is available in the section Applications of the F-I/O module (Page 32).

You can find information on wiring the front connectors and creating the cable shielding, etc., in the Wiring section of the system manual Automation System S7-1500 (<http://support.automation.siemens.com/WW/view/en/59191792>).

Block diagram

The following figure shows the assignment of channels to addresses (input byte a and input byte b).

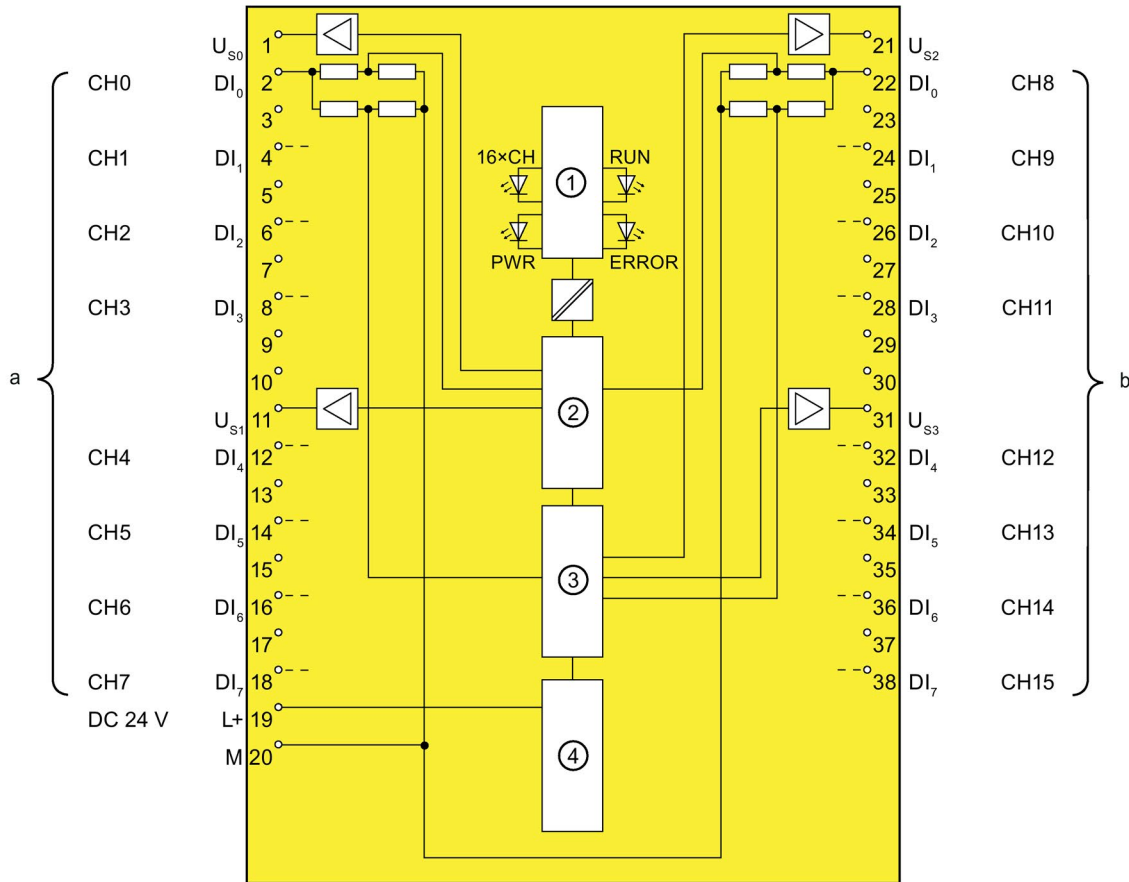

- |                 |                             |       |   |
|-----------------|-----------------------------|-------|---|
| ①               | Backplane bus interface     | L+    | Supply voltage 24 V DC  |
| ②               | Microcontroller 1           | M     | Chassis ground  |
| ③               | Microcontroller 2           | CH    | Channel or LED channel status, channel diagnostics (green, red) |
| ④               | Reverse polarity protection | PWR   | LED supply voltage (green)                                      |
| U <sub>Sn</sub> | Internal sensor supply n    | RUN   | RUN LED (green)   |
| DI <sub>n</sub> | Input bit n                 | ERROR | LED module diagnostics (red)                                    |

Image 3-1 Block diagram of the F-DI 16x24VDC



# Parameters/address space

## 4.1 Parameters

### Parameters

 **WARNING**

Diagnostic functions must be activated or deactivated in accordance with the application, see section Applications of the F-I/O module (Page 32).

Table 4- 1 Parameters for F-DI 16x24VDC

Parameter	Value range	Parameter reas- signment in RUN	Scope
<b>F-parameters:</b>			
Manual assignment of F-monitoring time	<ul style="list-style-type: none"> <li>• Disable</li> <li>• Enable</li> </ul>	No	Module
F-monitoring time	1 to 65535 ms	No	Module
F-source address	1 to 65534	No	Module
F-destination address	1 to 65534	No	Module
F-parameter signature (without address)	0 to 65535	No	Module
Behavior after channel fault	<ul style="list-style-type: none"> <li>• Passivate channel</li> <li>• Passivate the entire module</li> </ul>	No	Module
Reintegration after channel fault	<ul style="list-style-type: none"> <li>• Adjustable</li> <li>• All channels automatically</li> <li>• All channels manually</li> </ul>	No	Module
F-I/O DB manual number assignment	<ul style="list-style-type: none"> <li>• Disable</li> <li>• Enable</li> </ul>	No	Module
F-I/O DB-number	—	No	Module
F-I/O DB name	—	No	Module
<b>DI parameters:</b>			
<b>Sensor supply</b>			

## 4.1 Parameters

Parameter	Value range	Parameter reassignment in RUN	Scope
Supplied channels	Sensor supply 0: <ul style="list-style-type: none"> <li>No channels</li> <li>Channels [0..3]</li> <li>Channels [0..7]</li> <li>Channels [0..15]</li> </ul> Sensor supply 1: <ul style="list-style-type: none"> <li>No channels</li> <li>Channels [4..7]</li> </ul> Sensor supply 2: <ul style="list-style-type: none"> <li>No channels</li> <li>Channels [8..11]</li> <li>Channels [8..15]</li> </ul> Sensor supply 3: <ul style="list-style-type: none"> <li>No channels</li> <li>Channels [12..15]</li> </ul>	No	Channel group
Short-circuit test activated	<ul style="list-style-type: none"> <li>Disable</li> <li>Enable</li> </ul>	No	Channel
Time for short-circuit test	0.9 ms to 2 s	No	Channel
Startup time of sensors after short-circuit test	0.9 ms to 2 s	No	Channel
<b>Channel parameters</b>			
<b>Channel n, n+8</b>			
Sensor evaluation	<ul style="list-style-type: none"> <li>1oo1 evaluation</li> <li>1oo2 evaluation, equivalent</li> <li>1oo2 evaluation, non-equivalent</li> </ul>	No	Channel pair
Discrepancy behavior	<ul style="list-style-type: none"> <li>Supply value 0</li> <li>Supply last valid value</li> </ul>	No	Channel pair
Discrepancy time	5 ms to 30 s	No	Channel pair
Reintegration after discrepancy error	<ul style="list-style-type: none"> <li>Test 0-signal not necessary</li> <li>Test 0-signal necessary</li> </ul>	No	Channel pair
<b>Channel n</b>			
Channel activated	<ul style="list-style-type: none"> <li>Enable</li> <li>Disable</li> </ul>	No	Channel

Parameter	Value range	Parameter reassignment in RUN	Scope
Input delay	<ul style="list-style-type: none"> <li>• 0.4 ms</li> <li>• 0.8 ms</li> <li>• 1.6 ms</li> <li>• 3.2 ms</li> <li>• 6.4 ms</li> <li>• 10.0 ms</li> <li>• 12.8 ms</li> <li>• 20.0 ms</li> </ul> <p>The provided value range depends on the parameter assignment of the employed sensor supply.</p>	No	Channel
Channel failure acknowledge	<ul style="list-style-type: none"> <li>• Manual</li> <li>• Automatic</li> </ul> <p>The value range offered depends on the F-CPU in use and on the configuration of the F-parameter "Reintegration after channel fault".</p>	No	Channel
Pulse extension	<ul style="list-style-type: none"> <li>• —</li> <li>• 0.5 s</li> <li>• 1 s</li> <li>• 2 s</li> </ul>	No	Channel
Chatter monitoring	<ul style="list-style-type: none"> <li>• Disable</li> <li>• Enable</li> </ul>	No	Channel
Number of signal changes	2 to 31	No	Channel
Monitoring window	0 to 100 s (If 0 s is configured, the monitoring window is 0.5 s long.)	No	Channel

## 4.2 Explanation of parameters

### 4.2.1 F-parameters

You must assign the PROFIsafe address (F-destination address together with F-source address) to the F-module before you put it into operation.

- You define the F-source address using the "Basis for PROFIsafe addresses" parameter in the F-CPU.
- An F-destination address unique throughout the CPU is automatically assigned for each F-module. You can manually change the F-destination addresses set in the hardware configuration.

You can find information on F-parameters for the F-monitoring time, the PROFIsafe address assignment (F-source address, F-destination address) and the F I/O DB in the manual SIMATIC Safety - Configuring and Programming (<http://support.automation.siemens.com/WW/view/en/54110126>).

#### 4.2.1.1 Behavior after channel fault

This parameter is used to specify whether the entire F-module is passivated or just the faulty channel(s) in the event of channel faults:

- "Passivate the entire module"
- "Passivate channel"

#### 4.2.1.2 Reintegration after channel fault

Use this parameter to select how the channels of the fail-safe module are reintegrated after a fault.

##### Use in S7-300/400 F-CPUs

This parameter is always set to "Adjustable" when you use the fail-safe module in S7-300/400 F-CPUs.

You make the required setting in the F-I/O DB of the fail-safe module.

##### Use in S7-1500 F-CPUs

When using the fail-safe module in S7-1500 F-CPUs, you set this parameter in the STEP 7 dialog of the fail-safe module:

- "Adjustable"
- "All channels automatically"
- "All channels manually"

If you have set the "Behavior after channel fault" parameter to "Passivate channel", you enable individual setting of the reintegration type per channel with the parameter assignment "Adjustable". The reintegration type of the respective channel is specified with the "Channel failure acknowledge" channel parameter.

If you have set the "Behavior after channel fault" parameter to "Passivate the entire module", you can only select the same reintegration type for all channels.

## 4.2.2 Parameters of the sensor supply

### 4.2.2.1 Supplied channels

With this parameter, you specify whether and which internal sensor supply supplies which channel groups. The choice taken applies to the entire channel group (CH0-3, 4-7, 8-11, 12-15).

The following options are available, for example:

Parameter assignment:		Meaning	Parameter assignment:	
Left-hand module side			Right-hand module side	
Sensor supply 0 supplies channels ...	Sensor supply 1 supplies channels ...		Sensor supply 2 supplies channels ...	Sensor supply 3 supplies channels ...
0 to 3	4 to 7	Each channel group is supplied by its own internal sensor supply.	8 to 11	12 to 15
0 to 7	-	The channel groups of the left-hand module side are supplied by the internal sensor supply $V_{S0}$ .	8 to 11	12 to 15
0 to 3	4 to 7	The channel groups of the right-hand module side are supplied by the internal sensor supply $V_{S2}$ .	8 to 15	-
0 to 7	-	The channel groups of the left-hand module side are supplied by the internal sensor supply $V_{S0}$ ; the channel groups of the right-hand module side are supplied by the internal sensor supply $V_{S2}$ .	8 to 15	-
0 to 15	-	All the channels of the module are supplied by the internal sensor supply $V_{S0}$ .	-	-

You can also supply the sensors by means of an external sensor supply (parameter "None").

The selection of an internal sensor supply is required for using the short-circuit test.

#### See also

Short-circuit test activated (Page 21)

Connecting (Page 15)

### 4.2.2.2 Short-circuit test activated

Here you enable the short-circuit detection for the channels of the F-module for which one of the internal sensor supplies is set ("Supplied channels").

The short-circuit test is always possible when you are using simple switches that do not have their own power supply. For switches with their own power supply, for example, 3/4-wire proximity switches or optical sensors with OSSD (Output Signal Switching Device) outputs, you must adapt the "Startup time of sensors after short-circuit test" parameter to match the sensor in use.

## 4.2 Explanation of parameters

The short-circuit detection switches off the internal sensor supply briefly. The length of the deactivation period is equivalent to the configured "Time for sensor test".

If a short-circuit is detected, the F-module triggers a diagnostic interrupt and the input is passivated.

The following short-circuits are detected:

- Short-circuit of input to L+
- Short-circuit of the input of another channel when it has a 1 signal
- Short-circuit between the input and sensor supply of another channel
- Short-circuit between the sensor supply and the sensor supply of another channel

If the short-circuit test is disabled, you must make your wiring short-circuit and cross-circuit proof or select a connection type (discrepancy, non-equivalent) which also detect the cross-circuits using discrepancy.

---

### Note

During the execution time of the short-circuit test (Time for short-circuit test + Startup time of sensors after short-circuit test), the last valid value of the input before the start of the short-circuit test is passed to the F-CPU. The activation of the short-circuit test thus affects the response time of the respective channel or channel pair.

---

### 4.2.2.3 Time for short-circuit test

#### Function

When the short-circuit test is enabled, the corresponding internal sensor supply is switched off for the configured time. If the module does not detect a "0" signal at the input within the configured time, a diagnostics alarm is generated.

Note the following during parameter assignment:

- If the channel is passivated, this may be due to excessively high capacitance between sensor supply and input. This consists of the capacitance per unit length of the cable and the capacitance of the employed sensor. If the connected capacitance is not discharged within the configured time, you need to adjust the "Time for short-circuit test" parameter.

---

### Note

During the execution time of the short-circuit test (Time for short-circuit test + Startup time of sensors after short-circuit test), the last valid value of the input before the start of the short-circuit test is passed to the F-CPU. The activation of the short-circuit test thus affects the response time of the respective channel or channel pair.

---

- The "Time for short-circuit test" has to be 0.5 ms greater than the set input delay.

#### 4.2.2.4 Startup time of sensors after short-circuit test

##### Function

In addition to the switch-off time ("Time for short-circuit test"), a startup time must be specified for performing the short-circuit test. You use this parameter to notify the module how long the utilized sensor needs to start up after turning on the internal sensor supply. This prevents an undefined input state due to transient reactions in the sensor.

Note the following during parameter assignment:

- This parameter must be greater than the transient recovery time of the employed sensor.
- Because the assigned time affects the response time of the module, we recommend that you set the time as short as possible but long enough so that your sensor can settle safely.
- The "Startup time of sensors after short-circuit test" must
  - be set to a value greater than the set input delay
  - be at least 1% of the "time for short-circuit test"
  - be 0.5 ms greater than the set input delay.

##### Requirement

The short-circuit test is enabled.

#### 4.2.3 Parameters of the channel pairs

##### 4.2.3.1 Sensor evaluation

##### Overview

Select the type of sensor evaluation with the "Evaluation of the sensors" parameter:

- 1oo1 evaluation
- 1oo2 evaluation, equivalent
- 1oo2 evaluation, non-equivalent

##### 1oo1 evaluation

With a 1oo1 evaluation, the sensor occupies only one input channel.

### 1oo2 evaluation, equivalent/non-equivalent

With a 1oo2 evaluation equivalent/non-equivalent, two input channels are occupied by:

- a two-channel equivalent/non-equivalent sensor
- Two single-channel sensors

The input signals are compared internally for equivalence or non equivalence.

Note that in 1oo2 evaluation, two channels are combined into a channel pair. The number of available process signals of the F-module is reduced accordingly. The evaluation result is provided in the bit of the lower-order channel of the channel pair (channel n).

### Discrepancy analysis

When using a two-channel sensor or two single-channel sensors which measure the same process variable, the sensors interact with a slight time delay due to the limited precision of their arrangement.

Discrepancy analysis for equivalence or non-equivalence is used for fail-safe inputs to detect errors caused by the time characteristic of two signals with the same functionality. The discrepancy analysis is initiated when different levels are detected in two associated input signals (when testing for non-equivalence: the same level). A check is made to determine whether the difference in levels (when testing for non equivalence: the same level) has disappeared after an assignable time period, the so-called discrepancy time. If not, there is a discrepancy error.

#### 4.2.3.2 Discrepancy behavior

### Function

For the "Discrepancy behavior", you assign the value that is supplied to the safety program in the F-CPU during a discrepancy between two relevant input channels, which means while discrepancy time is running. You assign the discrepancy behavior as follows:

- "Supply last valid value"
- "Supply value 0"

### Requirements

You have assigned the following:

- "Sensor evaluation": "1oo2 evaluation, equivalent" or "1oo2 evaluation, non-equivalent"



### Supply last valid value"

The most recent valid value (old value) before the discrepancy occurred is made available to the safety program in the F-CPU as soon as a discrepancy is detected between the signals of the two affected input channels. This value is supplied until the discrepancy disappears or the discrepancy time expires and a discrepancy error is detected. The sensor-actuator response time is correspondingly increased by this time.

This means the discrepancy time of connected sensors with 1oo2 evaluation must be adjusted to fast response times. It makes no sense, for example, if connected sensors with a discrepancy time of 500 ms trigger a time-critical shutdown. In the worst-case scenario, the sensor-actuator response time is extended by an amount approximately equal to the discrepancy time:

- For this reason, position the sensors in the process in such a way as to **minimize discrepancy**.
- Then select the **shortest possible** discrepancy time which is also sufficient to compensate for faulty triggering of discrepancy errors.

### "Supply value 0"

As soon as a discrepancy between the signals of the two relevant input channels is detected, the value "0" is made available to the safety program in the F-CPU.

If you have set "Supply value 0", the sensor-actuator response time is not affected by the discrepancy time.

### 4.2.3.3 Discrepancy time

#### Function

You can set the discrepancy time for each channel pair.

#### Requirements

You have assigned the following:

- "Sensor evaluation": "1oo2 evaluation, equivalent" or "1oo2 evaluation, non-equivalent"

In most cases, a discrepancy time is started, but does not fully expire because the signal differences are cleared within a short time.

- Set the discrepancy time high enough that in the error-free case the difference between the two signals (when testing for non equivalence: the same levels) has always disappeared before the discrepancy time has expired.

#### Behavior while discrepancy time is running

While the programmed discrepancy time is running internally on the module, either the **last valid value** or "0" is returned to the safety program on the F-CPU by the input channels involved, depending on the parameter settings for the behavior at discrepancy.

### Behavior after expiration of the discrepancy time

If no agreement (when checking for non equivalence: inequality) of the input signals exists once the assigned discrepancy time expires, for example, due to a break in a sensor wire, a discrepancy error is detected and the "Discrepancy error" diagnostic message containing information on which channels are faulty is generated.

#### 4.2.3.4 Reintegration after discrepancy error

##### Function

This parameter specifies the criteria for when a discrepancy error is regarded as corrected, thus enabling reintegration of the relevant input channels. The following parameter assignment options are available:

- "Test 0-Signal necessary"
- "Test 0-Signal not necessary"

##### Requirements

You have assigned the following:

- "Sensor evaluation": "1oo2 evaluation, equivalent" or "1oo2 evaluation, non-equivalent"

##### "Test 0-Signal necessary"

If you have assigned "Test 0-signal necessary", a discrepancy error is not regarded as corrected until a 0-signal is present at both of the relevant input channels.

If you are using non equivalent sensors, which means you have set "Sensor evaluation" to "1oo2 evaluation, non-equivalent", the result of the channel pair must provide a 0-Signal again.

##### "Test 0-Signal not necessary"

If you have assigned "Test 0-Signal not necessary", a discrepancy error is regarded as corrected when a discrepancy no longer exists at both of the relevant input channels.

#### 4.2.4 Parameters of the channels

##### 4.2.4.1 Channel activated

You hereby enable the corresponding channel for signal processing in the safety program.

#### 4.2.4.2 Input delay

##### Function

To suppress injected interference, you can set an input delay for a channel or a channel pair. Interference pulses whose pulse time is less than the set input delay (in ms) are suppressed. Suppressed interference pulses are not visible in the process image input (PII).

A high input delay suppresses longer interference pulses, but results in a longer response time.

The set value for the input delay has to be smaller than the configured "Startup time of sensors after short-circuit test" and smaller than the configured "Time for short-circuit test".

With 1oo2 evaluation, the input delay of the lower-order channel (channel n) automatically applies to the higher-order channel (channel n+8).

---

##### Note

If there is an input delay < 3.2 ms, you have to use shielded cables.

---

##### Note

Due to the physical properties, there is a possibility of crosstalk between signals in the case of long, unshielded signal lines (see section "Electromagnetic compatibility" in the system manual S7-1500 Automation System (<http://support.automation.siemens.com/WW/view/en/59191792>)).

If the interference pulses occur with a short-circuit test, the fail-safe digital inputs are passivated. Increase the input delay or use shielded signal lines in order to prevent possible passivation of the fail-safe digital inputs and switch-off of the internal sensor supply.

---

##### See also

Technical specifications (Page 57)

Response times (Page 60)

#### 4.2.4.3 Channel failure acknowledge

##### Use in S7-1500 F-CPU

This parameter is only relevant if the fail-safe module is operated on an S7-1500 F-CPU, and can only be set if the F-parameter "Behavior after channel fault" is set to "Passivate channel" and the F-parameter "Reintegration after channel fault" is set to "Adjustable".

The value of this parameter specifies how the channel should react to a channel fault:

- Manual: A channel failure is reintegrated after manual acknowledgment.
- Automatically: The channel is reintegrated automatically after a channel fault. Manual acknowledgment is not necessary.

##### Use in S7-300/400 F-CPU

The value of this parameter is not relevant in the case of operation on S7-300/400 F-CPU. There you set the corresponding property at the F-I/O DB by means of the ACK\_NEC tag.

For detailed information about the F-I/O DB, refer to the SIMATIC Safety – Configuring and Programming (<http://support.automation.siemens.com/WWW/view/en/54110126>) manual.

#### 4.2.4.4 Pulse extension

##### Function

Pulse extension is a function to extend a digital input signal. A pulse on a digital input is extended to at least the assigned length. If the input pulse is already longer than the assigned length, the pulse is not changed.

The fail-safe electronic module only lengthens pulses with the value "0" because the basis of the safety concept is that there is a safe state for all process variables. For digital F-I/O, this is the value "0", which applies to sensors as well as to actuators.

The pulse extension can only be configured with 1oo1 evaluation.

#### 4.2.4.5 Chatter monitoring

##### Function

Chatter monitoring is a process control function for digital input signals. It detects and reports unusual signal sequences in the process with 1oo1 evaluation, for example, an input signal fluctuating between "0" and "1" too frequently. The occurrence of such signal characteristics is an indication of faulty sensors or process control instability.

## Recognizing unusual signal patterns

An assigned monitoring window is available for each input channel. The monitoring window starts with the first signal change of the input signal. If the input signal changes within the monitoring window at least as often as the assigned "Number of signal changes", a chatter error is detected. If no chatter error is detected within the monitoring window, the next signal change restarts the monitoring window.

If a chatter error is detected, a diagnostic is signaled. If the chatter error does not occur for the monitoring window for three times the configured period, the diagnostic is reset.

## Principle

The figure below shows the principle of chatter monitoring as a graphic.

Parameter for number of signal changes = 8

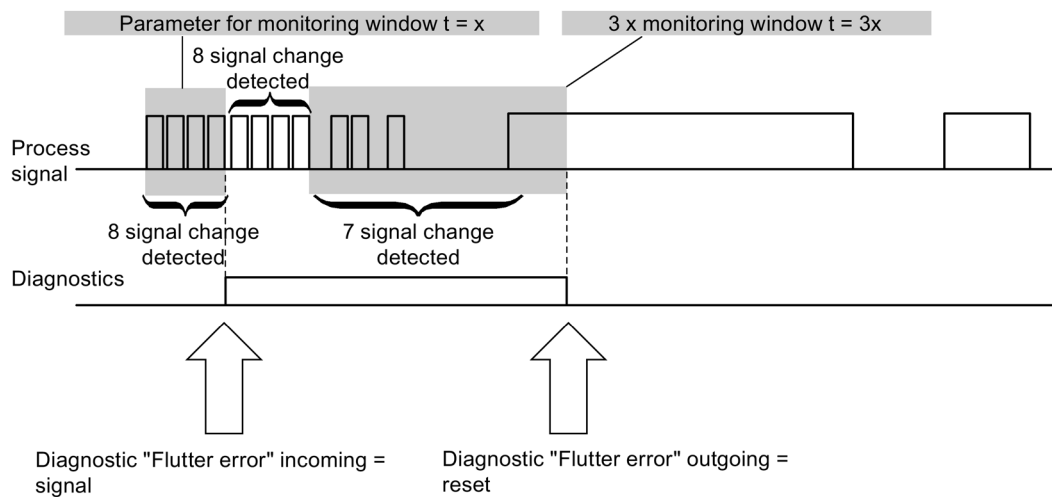

Image 4-1 Figure chatter monitoring

### 4.2.4.6 Number of signal changes

Sets the number of signal changes after which a chatter error should be reported (value range: 2 to 31).

### 4.2.4.7 Monitoring window

Sets the time for the monitoring window of flutter monitoring.

You can set times of 1 s to 100 s in whole seconds for the monitoring window.

Enter 0 to configure a monitoring window of 0.5 s.

## 4.3 Address space

### Address assignment of the digital input module F-DI 16x24VDC

The digital input module F-DI 16x24VDC occupies the following address areas in the F-CPU:

Table 4- 2 Address assignment in the F-CPU

Occupied bytes in the F-CPU:		
F-CPU	In input range	In output range
S7-300/400 F-CPU's	IB x + 0 to x + 7	QB x + 0 to x + 3
S7-1500 F-CPU's	IB x + 0 to x + 8	QB x + 0 to x + 4

x = Module start address

### Address assignment of the user data and the value status of digital input module F-DI 16x24VDC

The user data occupies the following addresses in the F-CPU out of all the assigned addresses of the digital input module F-DI 16x24VDC:

Table 4- 3 Address assignment through user data

Byte in the F-CPU	Assigned bits in F-CPU per F-module:							
	7	6	5	4	3	2	1	0
<b>IB x + 0</b> Channel group a	DI <sub>7</sub> (CH7)	DI <sub>6</sub> (CH6)	DI <sub>5</sub> (CH5)	DI <sub>4</sub> (CH4)	DI <sub>3</sub> (CH3)	DI <sub>2</sub> (CH2)	DI <sub>1</sub> (CH1)	DI <sub>0</sub> (CH0)
<b>IB x + 1</b> Channel group b	DI <sub>7</sub> (CH15)	DI <sub>6</sub> (CH14)	DI <sub>5</sub> (CH13)	DI <sub>4</sub> (CH12)	DI <sub>3</sub> (CH11)	DI <sub>2</sub> (CH10)	DI <sub>1</sub> (CH9)	DI <sub>0</sub> (CH8)
<b>IB x + 2</b> Channel group a	Value status for DI <sub>7</sub> (CH7)	Value status for DI <sub>6</sub> (CH6)	Value status for DI <sub>5</sub> (CH5)	Value status for DI <sub>4</sub> (CH4)	Value status for DI <sub>3</sub> (CH3)	Value status for DI <sub>2</sub> (CH2)	Value status for DI <sub>1</sub> (CH1)	Value status for DI <sub>0</sub> (CH0)
<b>IB x + 3</b> Channel group b	Value status for DI <sub>7</sub> (CH15)	Value status for DI <sub>6</sub> (CH14)	Value status for DI <sub>5</sub> (CH13)	Value status for DI <sub>4</sub> (CH12)	Value status for DI <sub>3</sub> (CH11)	Value status for DI <sub>2</sub> (CH10)	Value status for DI <sub>1</sub> (CH9)	Value status for DI <sub>0</sub> (CH8)

x = Module start address

---

**Note**

You may only access the addresses occupied by user data and value status.

The other address areas occupied by the F-modules are assigned for functions including safety-related communication between the F-modules and F-CPU in accordance with PROFIsafe.

1oo2 evaluation of the sensors combines the two channels, e.g. CH0 (input bit DI<sub>0</sub> in channel group a) with CH8 (input bit DI<sub>0</sub> in channel group b). With 1oo2 evaluation of the sensors, you may only access the input bit from channel group a in the safety program, in this example CH0.

---

**Additional information**

For detailed information about F-I/O access and for evaluation and processing of the value status, refer to the SIMATIC Safety – Configuring and Programming (<http://support.automation.siemens.com/WW/view/en/54110126>) manual.

## Applications of the F-I/O module

### 5.1 Applications of the F-DI 16x24VDC

#### Selecting the application

The diagram below supports you in selecting the application that suits your fail-safe requirements. In the following sections, you will learn how to wire the F-module, the specific parameters you must assign in STEP 7 Safety and the errors that are detected.

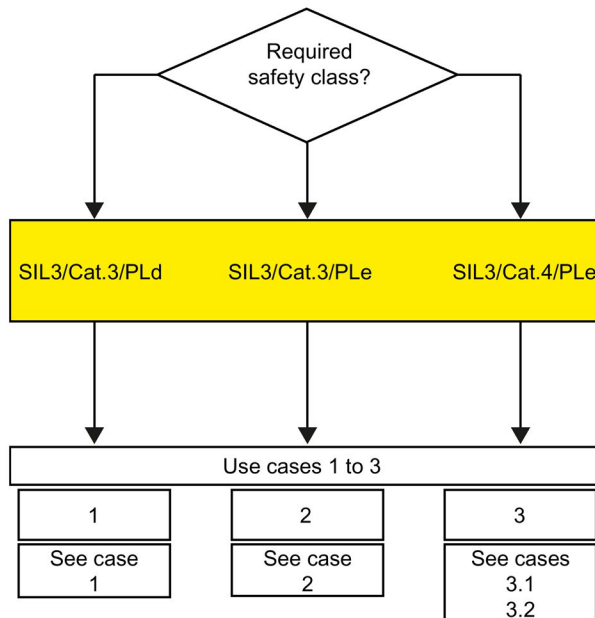

Image 5-1 Selecting the application – digital input module F-DI 16x24VDC

<b>⚠ WARNING</b>
The achievable safety class depends on the quality of the sensor and the duration of the mission time in accordance with IEC 61508:2010. If the quality of the sensor is lower than the quality required by the safety class, redundant sensors connected via two channels must be used and evaluated.



## Conditions for achieving SIL/Cat./PL

The table below lists the conditions which have to be met for achieving at least the corresponding safety requirements.

Table 5- 1 Conditions for achieving SIL/Cat./PL

Application	Sensor evaluation	Sensor supply	Achievable SIL/Cat./PL
1	1oo1	Any	3 / 3 / d
2	1oo2 equivalent	Internal, without short-circuit test	3 / 3 / e
		External	
3.1	1oo2 equivalent	Internal, with short-circuit test	3 / 4 / e
3.2	1oo2 non-equivalent	External or internal, with short-circuit test	

### Note

You can operate the various inputs of an F-DI module simultaneously in SIL3/Cat.3/PLd **and** in SIL3/Cat.3 or Cat.4/PLe. You only have to interconnect the inputs and assign parameters as described in the following sections.

## Sensor requirements

Information on the safety-related use of sensors is available in the section Requirements for sensors and actuators for fail-safe modules of the system manual S7-1500 Automation System (<http://support.automation.siemens.com/WW/view/en/59191792>).

## 5.2 Application 1: Safety mode SIL3/Cat.3/PLd

### Wiring

The wiring is carried out on the front connector of the module. Refer to the "Wiring" section in the S7-1500 Automation System (<http://support.automation.siemens.com/WW/view/en/59191792>) system manual.

### Sensor supply

The sensor supply can be powered internally or externally.

### Wiring diagram – connecting one sensor via one channel

One sensor is connected via one channel (1oo1 evaluation) for each process signal.

The assignment of the input to an internal sensor supply of the module must take place according to the parameter assignment "Supplied channels" (see section Supplied channels (Page 21)).

You can also supply the sensor by means of an external sensor supply.

The figure below shows an example of the pin assignment of the fail-safe digital input module F-DI 16x24VDC with one-channel connection of a sensor.

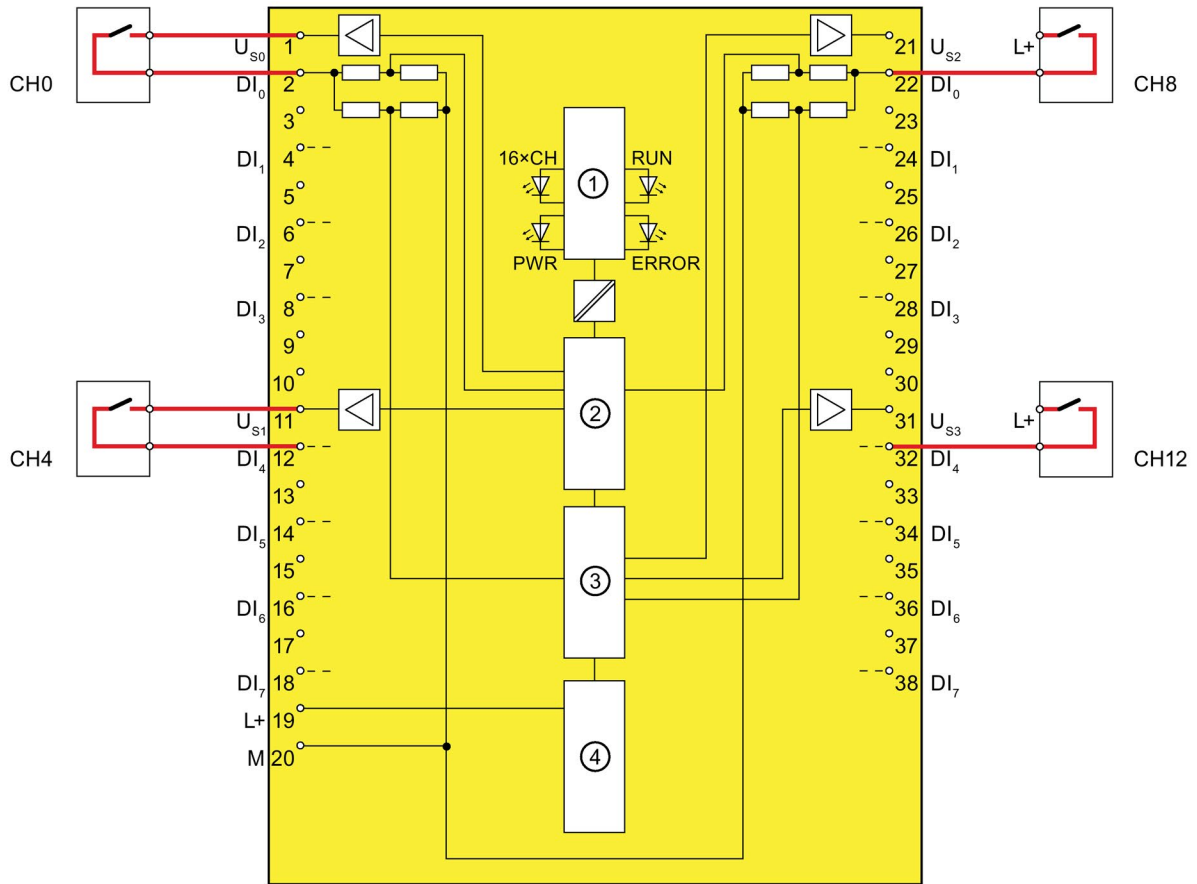

- ① Backplane bus interface
- ② Microcontroller 1
- ③ Microcontroller 2
- ④ Reverse polarity protection

Image 5-2 One sensor connected via one channel, internal sensor supply (left) or external sensor supply (right)

**WARNING**

To achieve SIL3/Cat.3/PLd using this wiring, you must use a qualified sensor.

### Parameter assignment

Assign the following parameters for the corresponding channel:

Table 5- 2 Parameter assignment

Parameter	Channel with internal sensor supply	Channel with external sensor supply
Sensor evaluation	1oo1 evaluation	
Supplied channels	Channels [x...y]	None
Short-circuit test activated	<ul style="list-style-type: none"> <li>• Disable</li> <li>• Enable*</li> </ul>	Disable

\*) optional. The selection of an internal sensor supply, however, is required for using the short-circuit test.

### Fault detection

The following table presents fault detection according to the sensor supply and the parameter assignment for the short-circuit test:

Table 5- 3 Fault detection

Fault	Fault detection		
	Internal sensor supply and short-circuit test activated	Internal sensor supply and short-circuit test deactivated	External sensor supply
Short-circuit of the input with other channels or other sensor supplies (short-circuit with other channels is detected only if they use a different sensor supply)	Yes*	No	No
Short-circuit between the input and associated sensor supply	No	No	No
Short-circuit with L+ to DI <sub>n</sub>	Yes	No	No
Short-circuit with M to DI <sub>n</sub>	No	No	No
Discrepancy error	—	—	—
Short-circuit with L+ to U <sub>Sn</sub>	Yes	No	—
Short-circuit with M to U <sub>Sn</sub> or defective	Yes	Yes	—

\*) Fault detection only if signals are corrupted. That is, the read signal differs from the sensor signal. If there is no signal corruption with respect to the sensor signal, fault detection is not possible and is not required from a safety standpoint.

 <b>WARNING</b>
If the short-circuit test is not activated or the sensor supply to digital inputs is set to "External sensor supply", the cable must be routed short-circuit proof.

### See also

Connecting (Page 15)

## 5.3 Application 2: Safety mode SIL3/Cat.3/PLe

### Assigning inputs to each other

The digital input module F-DI 16x24VDC has 16 fail-safe inputs, DI<sub>0</sub> to DI<sub>15</sub> (SIL3). You can combine two of these inputs each to one input.

You can combine the following inputs:

- DI<sub>0</sub> and DI<sub>8</sub>
- DI<sub>1</sub> and DI<sub>9</sub>
- DI<sub>2</sub> and DI<sub>10</sub>
- DI<sub>3</sub> and DI<sub>11</sub>
- DI<sub>4</sub> and DI<sub>12</sub>
- DI<sub>5</sub> and DI<sub>13</sub>
- DI<sub>6</sub> and DI<sub>14</sub>
- DI<sub>7</sub> and DI<sub>15</sub>

The process signals are provided by channels DI<sub>0</sub>, DI<sub>1</sub>, DI<sub>2</sub>, DI<sub>3</sub>, DI<sub>4</sub>, DI<sub>5</sub>, DI<sub>6</sub> and DI<sub>7</sub>.

---

#### Note

You can mix 1oo1 evaluation and 1oo2 evaluation in an F-DI module. You must interconnect and parameterize the inputs according to the fail-safe requirements (SIL3/Cat.3/PLd and SIL3/Cat.3 or Cat.4/PLe).

---

### Wiring

The wiring is carried out on the front connector of the module. Refer to the "Wiring" section in the S7-1500 Automation System (<http://support.automation.siemens.com/WW/view/en/59191792>) system manual.

### Sensor supply

The sensor supply can be powered internally or externally.

**Wiring diagram – connecting a two-channel sensor equivalent**

A two-channel sensor is connected equivalent to two inputs of the F-module for each process signal (1oo2 evaluation).

You can also supply one or both sensor switches by means of an external sensor supply.

The figure below shows an example of the pin assignment of the fail-safe digital input module F-DI 16x24VDC with equivalent connection of a two-channel sensor.

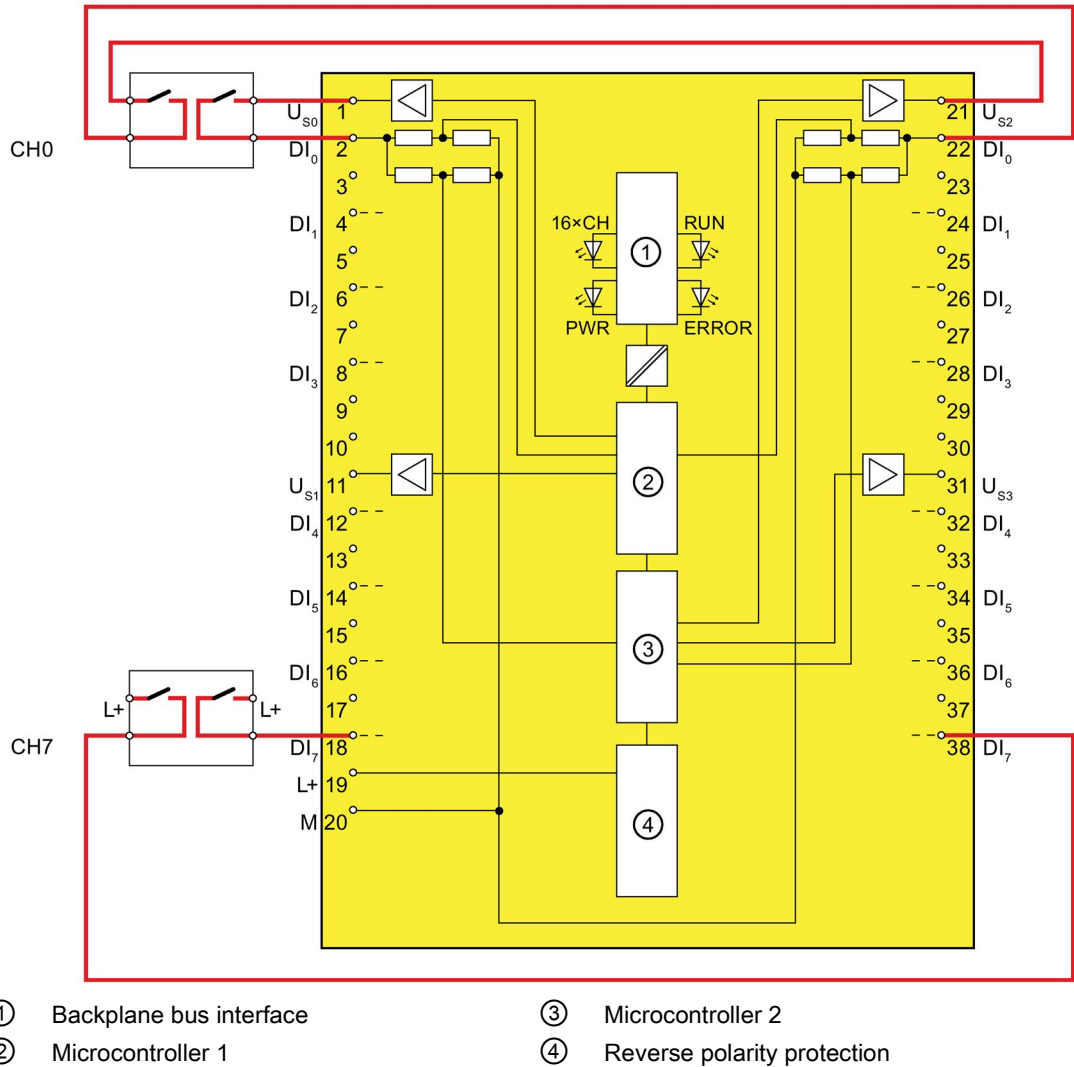

Image 5-3 One two-channel sensor connected equivalently, internal sensor supply (top) or external sensor supply (bottom)

**Wiring diagram – connecting two single-channel sensors via two channels**

Two single-channel sensors that capture the same process value are connected to two inputs of the F-module for each process signal (1oo2 evaluation).

You can also supply the sensors by means of an external sensor supply.

The figure below shows an example of the pin assignment of the fail-safe digital input module F-DI 16x24VDC with two-channel connection of two single-channel sensors.

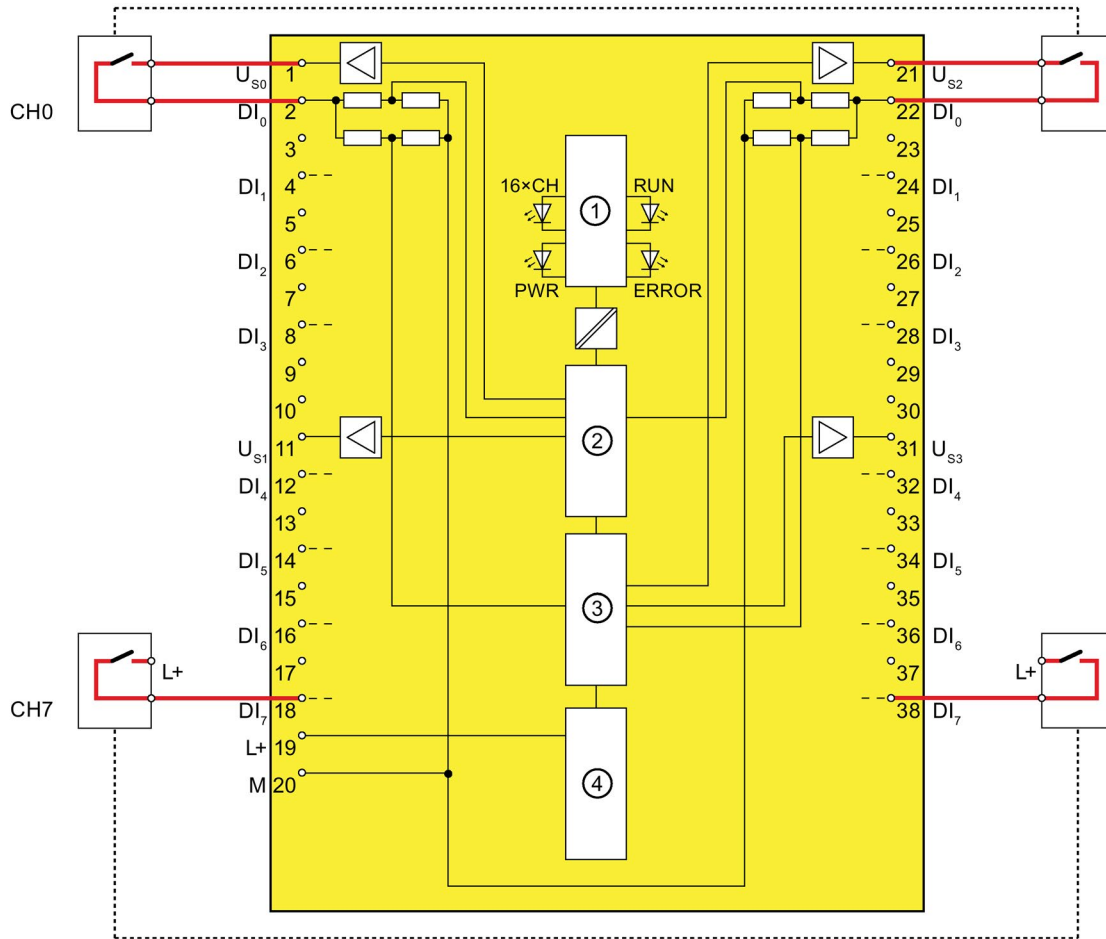

- ① Backplane bus interface
- ② Microcontroller 1
- ③ Microcontroller 2
- ④ Reverse polarity protection

Image 5-4 Two single-channel sensors connected via two channels, internal sensor supply (top) or external sensor supply (bottom)

**⚠ WARNING**

To achieve SIL3/Cat.3/PLe using this wiring, you must use a qualified sensor.

## Parameter assignment

Assign the following parameters for the corresponding channel:

Table 5- 4 Parameter assignment

Parameter	Channel with internal sensor supply	Channel with external sensor supply
Sensor evaluation	1oo2 evaluation, equivalent	
Supplied channels	Channels [x...y]	None
Short-circuit test activated	Disable	

## Fault detection

The following table presents fault detection according to the sensor supply and the parameter assignment for the short-circuit test:

Table 5- 5 Fault detection

Fault	Fault detection	
	Internal sensor supply and short-circuit test deactivated	External sensor supply
Short-circuit within the channel pair	No	No
Short-circuit with other channels or other sensor supplies	Yes*	Yes
Short-circuit with L+ to DI <sub>n</sub>	Yes*	Yes*
Short-circuit with M to DI <sub>n</sub>	Yes*	Yes*
Discrepancy error	Yes	Yes
Short-circuit with L+ to U <sub>Sn</sub>	No	No
Short-circuit with M to U <sub>Sn</sub> or defective	Yes	—

\*) Fault detection only if signals are corrupted. That is, the read signal differs from the sensor signal (discrepancy error). If there is no signal corruption with respect to the sensor signal, fault detection is not possible and is not required from a safety standpoint.

## See also

Connecting (Page 15)



## 5.4 Application 3: Safety mode SIL3/Cat.4/PLe

### Assigning inputs to each other

The digital input module F-DI 16x24VDC has 16 fail-safe inputs, DI<sub>0</sub> to DI<sub>15</sub> (SIL3). You can combine two of these inputs each to one input.

You can combine the following inputs:

- DI<sub>0</sub> and DI<sub>8</sub>
- DI<sub>1</sub> and DI<sub>9</sub>
- DI<sub>2</sub> and DI<sub>10</sub>
- DI<sub>3</sub> and DI<sub>11</sub>
- DI<sub>4</sub> and DI<sub>12</sub>
- DI<sub>5</sub> and DI<sub>13</sub>
- DI<sub>6</sub> and DI<sub>14</sub>
- DI<sub>7</sub> and DI<sub>15</sub>

The process signals are provided by channels DI<sub>0</sub>, DI<sub>1</sub>, DI<sub>2</sub>, DI<sub>3</sub>, DI<sub>4</sub>, DI<sub>5</sub>, DI<sub>6</sub> and DI<sub>7</sub>.

### Wiring

The wiring is carried out on the front connector of the module. Refer to the "Wiring" section in the S7-1500 Automation System

(<http://support.automation.siemens.com/WW/view/en/59191792>) system manual.

### Sensor supply

The sensor must be supplied internally by at least one channel group for application 3.1.

The sensor can be supplied internally or externally for application 3.2.

### Requirements for applications in machine protection with Cat.4

Both conditions must be met for applications in machine protection with Cat.4:

- The wiring between sensors and automation system and between automation system and actuators must be designed with state-of-the-art engineering and standards to prevent short-circuits.
- The sensors must be wired as shown in sections Application 3.1 (SIL3/Cat.4/PLe) (Page 42) or Use case 3.2 (SIL3/Cat.4/PLe) (Page 44). You only need to detect **one** short-circuit because 2 faults are required to generate it. This means both signal cables in short-circuit have an isolation fault. A multiple short-circuit analysis is not required.

Procedures for locating all short-circuits are also permitted if single short-circuits are not located. One of the two conditions must be met for this purpose:

- Short-circuits may not corrupt the read signals compared to the sensor signals.
- Short-circuits cause a corruption of the read signals compared to sensor signals in the direction that ensures safety.

### See also

Connecting (Page 15)

### 5.4.1 Application 3.1 (SIL3/Cat.4/PLe)

#### Wiring diagram – connecting a two-channel sensor via two channels

A two-channel sensor is connected to two inputs of the F-module for each process signal (1oo2 evaluation).

Supply the sensors from two different internal sensor supplies.

Alternatively, two single-channel sensors can be connected via two channels. In this case, the same process variable is acquired with two mechanically separate sensors.

The figure below shows an example of the pin assignment of the fail-safe digital input module F-DI 16x24VDC with two-channel connection of one two-channel sensor or two single-channel sensors.

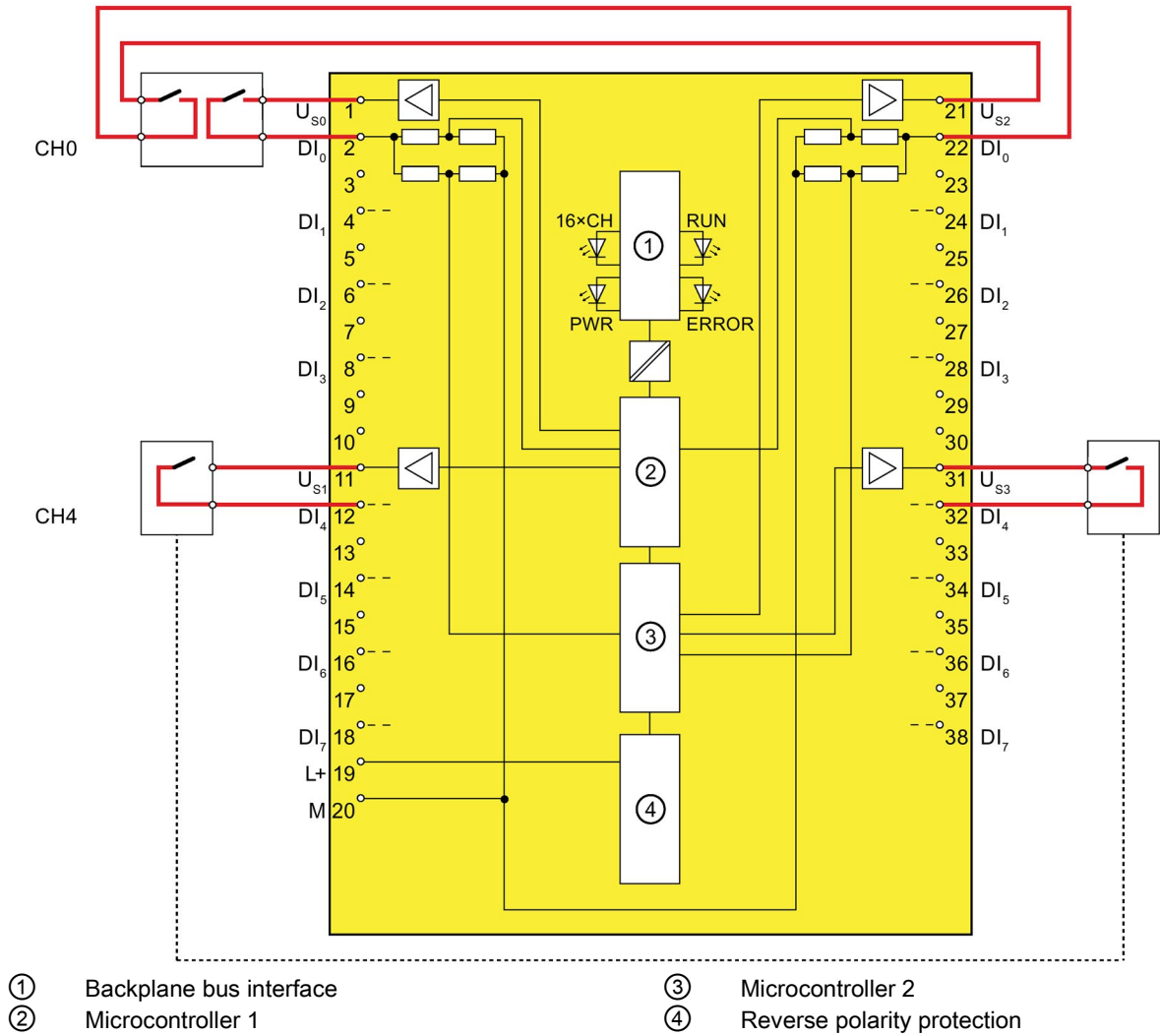

Image 5-5 One two-channel sensor connected via two channels (top) or two single-channel sensors connected via two channels (bottom); internal sensor supply

	<b>WARNING</b>
To achieve SIL3/Cat.4/PLe using this wiring, you must use a suitably qualified sensor.	

## Parameter assignment

Assign the following parameters for the corresponding channel:

Table 5- 6 Parameter assignment

Parameter	Channel with internal sensor supply
Sensor evaluation	1oo2 evaluation, equivalent
Supplied channels	Channels [x...y]
Short-circuit test activated	Enable

## Fault detection

The following table presents fault detection according to the sensor supply and the parameter assignment for the short-circuit test:

Table 5- 7 Fault detection

Fault	Fault detection
	Internal sensor supply and short-circuit test activated
Short-circuit within the channel pair	No
Short-circuit with other channels or other sensor supplies	Yes*
Short-circuit with L+ to DI <sub>n</sub>	Yes* / Yes (for channel whose short-circuit test is activated)
Short-circuit with M to DI <sub>n</sub>	Yes*
Discrepancy error	Yes
Short-circuit with L+ to U <sub>Sn</sub>	Yes
Short-circuit with M to U <sub>Sn</sub> or defective	Yes

\*) Fault detection only if signals are corrupted. That is, the read signal differs from the sensor signal (discrepancy error). If there is no signal corruption with respect to the sensor signal, fault detection is not possible and is not required from a safety standpoint.

### 5.4.2 Use case 3.2 (SIL3/Cat.4/PLe)

#### Wiring diagram – connecting a non-equivalent sensor

A non-equivalent sensor is connected to two inputs of the F-module for each process signal (1oo2 evaluation, non-equivalent).

You can also supply the sensor by means of an external sensor supply.

The figure below shows an example of the pin assignment of the fail-safe digital input module F-DI 16x24VDC with connection of a non-equivalent sensor.

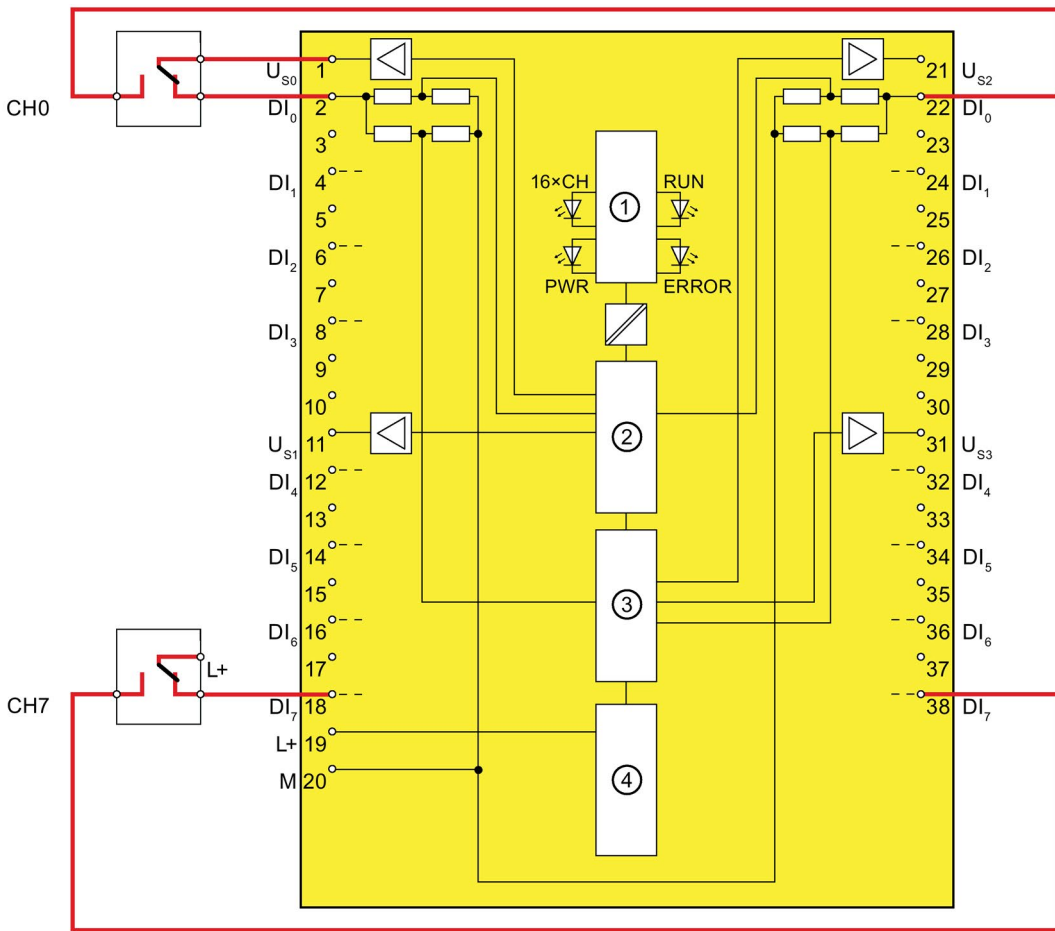

- ① Backplane bus interface
- ② Microcontroller 1
- ③ Microcontroller 2
- ④ Reverse polarity protection

Image 5-6 One non-equivalent sensor connected, internal sensor supply (top) or external sensor supply (bottom)

**⚠ WARNING**

To achieve SIL3/Cat.4/PLe using this wiring, you must use a suitably qualified sensor.

**Wiring diagram – connecting two single-channel sensors non-equivalent**

Two single-channel sensors are connected non-equivalent to two inputs of the F-module for each process signal (1oo2 evaluation).

You can also supply one or both sensors by means of an external sensor supply.

The figure below shows an example of the pin assignment of the fail-safe digital input module F-DI 16x24VDC with non-equivalent connection of two single-channel sensors.

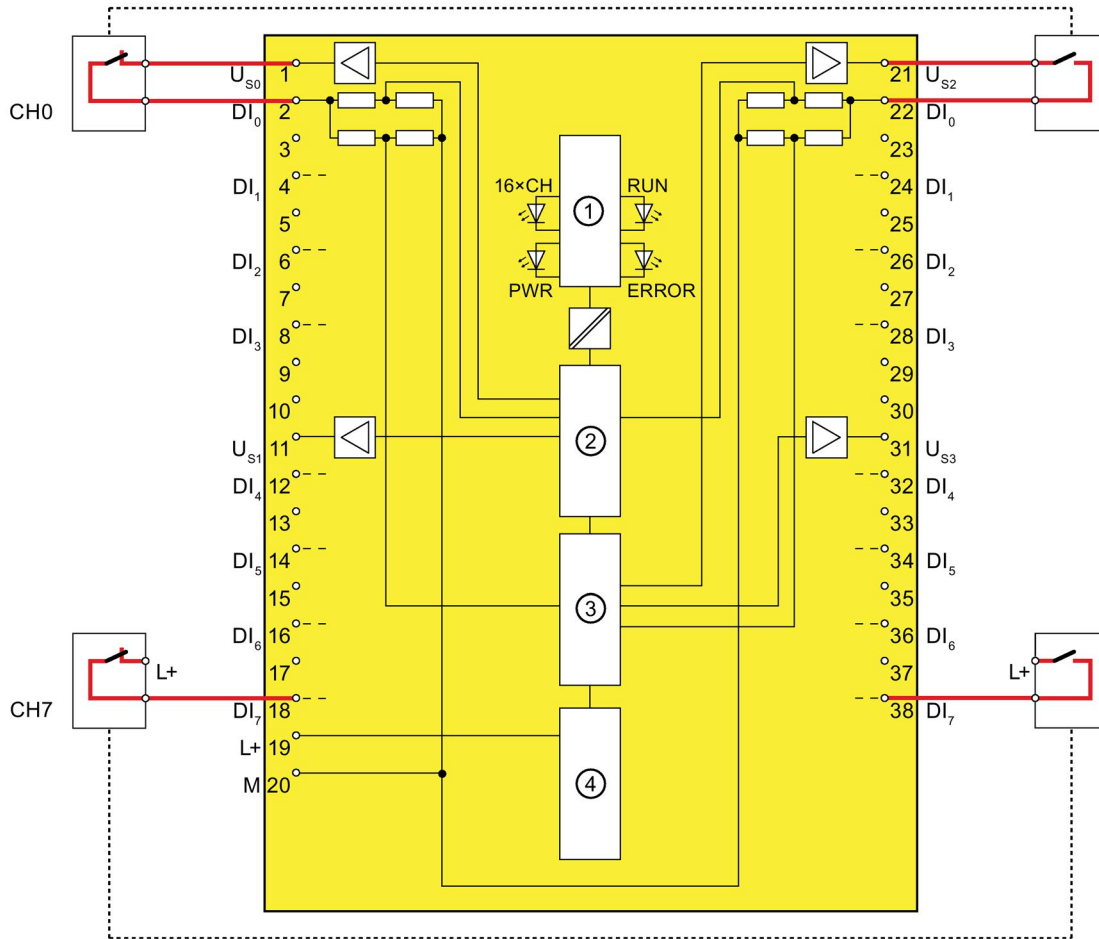

- ① Backplane bus interface
- ② Microcontroller 1
- ③ Microcontroller 2
- ④ Reverse polarity protection

Image 5-7 Two single-channel sensors connected non-equivalently, internal sensor supply (top) or external sensor supply (bottom)

**⚠ WARNING**

To achieve SIL3/Cat.4/PLe using this wiring, you must use a suitably qualified sensor.

## Parameter assignment

Assign the following parameters for the corresponding channel:

Table 5- 8 Parameter assignment

Parameter	Channel with internal sensor supply	Channel with external sensor supply
Sensor evaluation	1oo2 evaluation, non-equivalent	
Supplied channels	Channels [x...y]	None
Short-circuit test activated	<ul style="list-style-type: none"> <li>• Disable</li> <li>• Enable*</li> </ul>	Disable

\*) optional. The selection of an internal sensor supply, however, is required for using the short-circuit test.

## Fault detection

The following table presents fault detection according to the sensor supply and the parameter assignment for the short-circuit test:

Table 5- 9 Fault detection

Fault	Fault detection
Short-circuit within the channel pair, with other channels or other sensor supplies	Yes
Short-circuit with L+ to DI <sub>n</sub>	yes* / yes (for channel whose short-circuit test is activated)
Short-circuit with M to DI <sub>n</sub>	Yes*
Discrepancy error	Yes
Short-circuit with L+ to U <sub>Sn</sub>	Yes, if internal sensor supply is used and short-circuit test activated
Short-circuit with M to U <sub>Sn</sub> or defective	Yes, if internal sensor supply is activated

\*) Fault detection only if signals are corrupted. That is, the read signal differs from the sensor signal (discrepancy error). If there is no signal corruption with respect to the sensor signal, fault detection is not possible and is not required from a safety standpoint.

## Interrupts/diagnostic messages

### 6.1 Status and error displays

#### LED displays

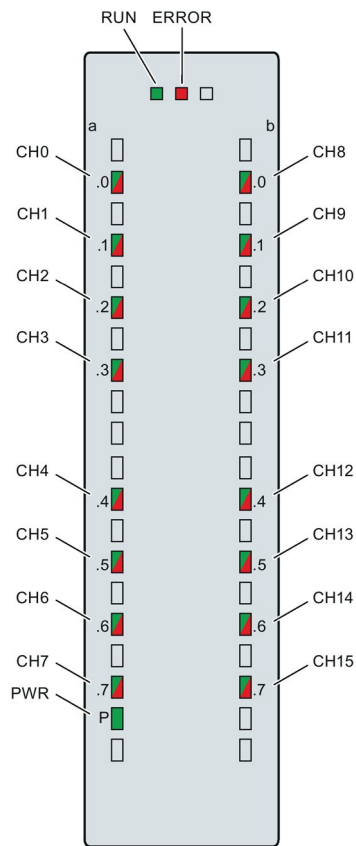



Image 6-1 LED displays of the F-DI 16x24VDC module

#### Meaning of the LED displays

The following tables explain the meaning of the status and error displays. Remedies for diagnostic alarms can be found in section Diagnostic alarms (Page 51).

 <b>WARNING</b>
<p>The RUN, ERROR LEDs and channel status/channel diagnostics LEDs of the inputs are not designed as safety-related LEDs and therefore may not be evaluated for safety-related activities.</p>

## RUN and ERROR LEDs

Table 6- 1 RUN and ERROR status and error displays

LED		Meaning	Remedy
RUN	ERROR		
□ Off	□ Off	Missing or insufficient voltage on the backplane bus	<ul style="list-style-type: none"> <li>Switch on the CPU and/or the system power supply modules.</li> <li>Check whether the module is correctly plugged into the U-connector.</li> <li>Check whether too many modules are plugged in.</li> </ul>
⚡ Flashing	□ Off	Module starts up and flashes up to the valid parameter assignment.	---
■ On	□ Off	Module parameters are assigned and module addressed.	
□ Off	⚡ Flashing	Firmware is being updated.	
■ On	⚡ Flashing	Indicates diagnostic interrupts: <ul style="list-style-type: none"> <li>Module fault (for example, supply voltage too high)</li> <li>Channel fault (for example, frequency too high).</li> <li>PROFIsafe communication error</li> </ul> Operation in S7-1500 F-CPU: At least one channel is waiting for user acknowledgment.	Evaluate the diagnostics and eliminate or acknowledge the error. It may be necessary to remove and re-insert the module.
⚡ Flashing	⚡ Flashing	Hardware defective.	Replace the module.
⚡/⚡ Alternately flashing		<ul style="list-style-type: none"> <li>Operation in S7-1500 F-CPU: The F-module expects user acknowledgment after a module error.</li> <li>Operation in S7-300/400 F-CPU: At least one channel is waiting for user acknowledgment.</li> </ul>	Acknowledge the error (see manual SIMATIC Safety - Configuring and Programming ( <a href="http://support.automation.siemens.com/WW/view/en/54110126">http://support.automation.siemens.com/WW/view/en/54110126</a> )).

## PWR LED

Table 6- 2 PWR status display

PWR LED	Meaning
□ Off	Supply voltage L+ missing
■ On	Supply voltage L+ available



## CHx LED



Table 6- 3 Display channel status/channel diagnostics

Status CHx	Diagnostics CHx	Meaning
□ Off	□ Off	Process signal = 0 and no channel diagnostics*
■ On	□ Off	Process signal = 1 and no channel diagnostics
□ Off	■ On	Process signal = 0 and channel diagnostics
 Alternately flashing		Channel waiting for user acknowledgment

\* Operation in S7-300/400 F-CPU's only: If necessary, wait for user acknowledgment, if an additional channel is also waiting for user acknowledgment due to an error that occurred later.

## CHx/Error LED with PROFIsafe address assignment

Table 6- 4 Channel status/channel diagnostics/Error display with PROFIsafe address assignment

Status CHx	Diagnostics CHx	ERROR	Meaning
□ Off	■ All on	 Flashing	The PROFIsafe address does not match the configured PROFIsafe address
 All are flashing	□ Off	 Flashing	Identification of the F-module when assigning the PROFIsafe address

## CHx/RUN/ERROR LED if supply voltage error occurs

Table 6- 5 Channel status/channel diagnostics/RUN/ERROR display if supply voltage error occurs

CHx status	Diagnostics CHx	RUN	ERROR	Meaning
□ Off	■ On	■ On	 Flashing	Supply voltage too high or too low. <ul style="list-style-type: none"> <li>• Operation in S7-1500 F-CPU's: Module is waiting for user acknowledgment.</li> <li>• Operation in S7-300/400 F-CPU's: Module is automatically reintegrated after the correction of the error.</li> </ul>

## 6.2 Interrupts

### Introduction

The F-DI 16x24VDC fail-safe digital input module supports diagnostic interrupts.

### Diagnostic interrupt

The F-module generates a diagnostic interrupt for each diagnostic alarm described in section Diagnostic alarms (Page 51).

The table below provides an overview of the diagnostic interrupts of the F-module . The diagnostic interrupts are assigned either to one channel or the entire F-module.

Table 6- 6 Diagnostic interrupts of the F-DI 16x24VDC

Diagnostic interrupt	Fault code	Signaled in application	Scope of diagnostic interrupt	Configurable
Overtemperature	5 <sub>D</sub>	1, 2, 3	F-module	No
Parameter error	16 <sub>D</sub>			
Supply voltage missing	17 <sub>D</sub>			
Mismatch of safety destination address (F_Dest_Add)	64 <sub>D</sub>			
Safety destination address not valid (F_Dest_Add)	65 <sub>D</sub>			
Safety source address not valid (F_Source_Add)	66 <sub>D</sub>			
Safety watchdog time value is 0 ms (F_WD_Time)	67 <sub>D</sub>			
Parameter F_SIL exceeds SIL from specific device application	68 <sub>D</sub>			
Parameter F_CRC_Length does not match the generated values	69 <sub>D</sub>			
Version of F-parameter set incorrectly	70 <sub>D</sub>			
CRC1 fault	71 <sub>D</sub>			
Save iParameter watchdog time exceeded	73 <sub>D</sub>			
Restore iParameter watchdog time exceeded	74 <sub>D</sub>			
Inconsistent iParameters (iParCRC error)	75 <sub>D</sub>			
F_Block_ID not supported	76 <sub>D</sub>			
Transmission error: Inconsistent data (CRC error)	77 <sub>D</sub>			
Transmission error: Timeout (watchdog time 1 or 2 expired)	78 <sub>D</sub>			
Module is defective	256 <sub>D</sub>			
Watchdog tripped	259 <sub>D</sub>			
Invalid/inconsistent firmware present	283 <sub>D</sub>			
Discrepancy failure, channel state 0/0	768 <sub>D</sub>	2, 3	Channel	
Discrepancy failure, channel state 0/1	769 <sub>D</sub>			
Discrepancy failure, channel state 1/0	770 <sub>D</sub>			
Discrepancy failure, channel state 1/1	771 <sub>D</sub>			
Input signal not recorded unique	773 <sub>D</sub>	1, 2, 3		

Diagnostic interrupt	Fault code	Signaled in application	Scope of diagnostic interrupt	Configurable	
Internal sensor supply short-circuit to P	774 <sub>D</sub>			Yes	
Overload or internal sensor supply short-circuit to ground	775 <sub>D</sub>				
Channel failure acknowledgment	779 <sub>D</sub>				
F-address memory not accessible	781 <sub>D</sub>			F-module	No
Sensor signal flutters	784 <sub>D</sub>	1	Channel	Yes	
Frequency too high	785 <sub>D</sub>		Channel	No	
Undertemperature	786 <sub>D</sub>			F-module	
Input shorted to P	796 <sub>D</sub>		Channel	Yes	
Supply voltage too high	801 <sub>D</sub>		F-module	No	
Supply voltage too low	802 <sub>D</sub>				

## 6.3 Diagnostic alarms

### Diagnostic alarms

Module faults are indicated as diagnostics (module status).

Once the fault is eliminated, the F-module must be reintegrated in the safety program. For additional information on passivation and reintegration of F-I/O, refer to the SIMATIC Safety – Configuring and Programming

(<http://support.automation.siemens.com/WW/view/en/54110126>) manual.

Table 6- 7 Diagnostic alarms of the F-DI 16x24VDC

Diagnostic alarm	Fault code	Meaning	Remedy
Overtemperature	5 <sub>D</sub>	An excessively high temperature was measured in the F-module.	Operate the F-module within the specified temperature range (see Technical specifications (Page 57)) Once the temperature has been reduced and returns to the specified range, the F-module must be removed and inserted or the power switched OFF and ON.
Parameter error	16 <sub>D</sub>	Parameter errors include: <ul style="list-style-type: none"> <li>The F-module cannot use the parameters (unknown, invalid combination, etc.).</li> <li>The F-module parameters have not been configured.</li> </ul>	Correct the parameter assignment.

6.3 Diagnostic alarms

Diagnostic alarm	Fault code	Meaning	Remedy
Supply voltage missing	17D	Missing or insufficient supply voltage L+	<ul style="list-style-type: none"> <li>Check supply voltage L+ at the front connector</li> <li>Check the front connector</li> </ul>
Mismatch of safety destination address (F_Dest_Add)	64D	The firmware of the F-module has detected a different F-destination address.	<ul style="list-style-type: none"> <li>Check the parameter assignment of the PROFIsafe driver and the PROFIsafe address assigned to the F-module.</li> <li>Assign the PROFIsafe address to the F-module (again).</li> </ul>
Safety destination address not valid (F_Dest_Add)	65D	The firmware of the F-module has detected an illegal different F-destination address.	
Safety source address not valid (F_Source_Add)	66D	The firmware of the F-module has detected a different F-source address.	
Safety watchdog time value is 0 ms (F_WD_Time)	67D	The firmware of the F-module has detected an invalid watchdog time.	
Parameter F_SIL exceeds SIL from specific device application	68D	The firmware of the F-module has detected a discrepancy between the SIL setting of the communication and the application.	
Parameter F_CRC_Length does not match the generated values	69D	The firmware of the F-module has detected a discrepancy in the CRC length.	
Version of F-parameter set incorrectly	70D	The firmware of the F-module has detected an incorrect F_Par_Version or an invalid F_Block_ID.	
CRC1 fault	71D	The firmware of the F-module has detected inconsistent F-parameters.	
Save iParameter watchdog time exceeded	73D	iPar server does not respond to "save iPar" within 4.4 minutes.	Check the parameter assignment of the iPar server.
Restore iParameter watchdog time exceeded	74D	iPar server does not respond to "restore iPar" within 4.4 minutes.	Check the parameter assignment of the iPar server.
Inconsistent iParameters (iParCRC error)	75D	The firmware of the F-module has detected inconsistent iParameters.	Check the parameter assignment.
F_Block_ID not supported	76D	The firmware of the F-module has detected an incorrect F_block_ID.	Check the parameter assignment of the PROFIsafe driver.
Transmission error: Inconsistent data (CRC error)	77D	<p>The firmware of the F-module has detected a CRC error.</p> <p>Possible causes:</p> <ul style="list-style-type: none"> <li>The communication between the F-CPU and F-module is disturbed.</li> <li>Impermissibly high electromagnetic interference is present.</li> <li>An error occurred in the sign-of-life monitoring.</li> </ul>	<ul style="list-style-type: none"> <li>Check the communication connection between the F-module and F-CPU.</li> <li>Eliminate the electromagnetic interference.</li> </ul>
Transmission error: Timeout (watchdog time 1 or 2 expired)	78D	<p>The firmware of the F-module has detected a timeout.</p> <p>Possible causes:</p> <ul style="list-style-type: none"> <li>The F-monitoring time is set incorrectly.</li> <li>A bus fault is present.</li> </ul>	<ul style="list-style-type: none"> <li>Check the parameter assignment.</li> <li>Ensure that communication is functioning correctly.</li> </ul>

Diagnostic alarm	Fault code	Meaning	Remedy
Module is defective	256 <sub>D</sub>	Possible causes: <ul style="list-style-type: none"> <li>Impermissibly high electromagnetic interference is present.</li> <li>The F-module has detected an internal error and has reacted in a safety-related manner.</li> </ul>	<ul style="list-style-type: none"> <li>Eliminate the interference. The module must then be pulled and plugged, or the power switched OFF and ON.</li> <li>If the F-module cannot be put back into operation, consider replacing it.</li> </ul>
Watchdog tripped	259 <sub>D</sub>	Possible causes: <ul style="list-style-type: none"> <li>Impermissibly high electromagnetic interference is present.</li> <li>The F-module has detected an internal error and has reacted in a safety-related manner.</li> </ul>	<ul style="list-style-type: none"> <li>Eliminate the interference. The module must then be pulled and plugged, or the power switched OFF and ON.</li> <li>If the F-module cannot be put back into operation, consider replacing it.</li> </ul>
Invalid/inconsistent firmware present	283 <sub>D</sub>	The firmware is incomplete and/or firmware added to the F-module is incompatible. This leads to errors or functional limitations when operating the F-module.	<ul style="list-style-type: none"> <li>Perform a firmware update for all parts of the F-module and note any error messages.</li> <li>Use only firmware versions released for this F-module.</li> </ul>
Discrepancy failure, channel state 0/0	768 <sub>D</sub>	Possible causes: <ul style="list-style-type: none"> <li>The process signal is faulty.</li> <li>The sensor is defective.</li> <li>The configured discrepancy time is too low.</li> <li>There is a short-circuit between an unconnected sensor cable and the sensor supply cable.</li> <li>Wire break in connected sensor cable or the sensor supply cable</li> <li>An error occurred during the discrepancy check.</li> </ul>	<ul style="list-style-type: none"> <li>Check the process signal.</li> <li>Replace the sensor.</li> <li>Check the parameter assignment of the discrepancy time.</li> <li>Check the process wiring.</li> </ul>
Discrepancy failure, channel state 0/1	769 <sub>D</sub>		
Discrepancy failure, channel state 1/0	770 <sub>D</sub>		
Discrepancy failure, channel state 1/1	771 <sub>D</sub>		

6.3 Diagnostic alarms

Diagnostic alarm	Fault code	Meaning	Remedy
Input signal not recorded unique	773 <sub>D</sub>	<p>An error occurred during the plausibility check of the input signal between the processors.</p> <p>Possible causes:</p> <ul style="list-style-type: none"> <li>• The input signal is faulty, e.g., as a result of impermissibly high electromagnetic interference.</li> <li>• A high-frequency input signal is present, e.g., due to mutual interference of sensors or the signal being above the sampling frequency of the input signal.</li> <li>• A momentary interruption/short-circuit of the sensor cable (loose contact) is present.</li> <li>• The sensor/switch is bouncing.</li> </ul>	<ul style="list-style-type: none"> <li>• Use shielded cables to reduce the EMC effects.</li> <li>• Reduce the input frequency.</li> <li>• Check the wiring of the sensor.</li> </ul>
Internal sensor supply short-circuit to P	774 <sub>D</sub>	<p>Possible causes:</p> <ul style="list-style-type: none"> <li>• There is a short-circuit of the internal sensor supply with L+.</li> <li>• There is a short-circuit of two sensor supplies.</li> <li>• The capacitance of the connected sensor for the configured test time is too high.</li> <li>• The sensor is defective.</li> </ul>	<ul style="list-style-type: none"> <li>• Eliminate the short-circuit in the process wiring.</li> <li>• Check the configured test time and the process wiring.</li> <li>• Replace the sensor.</li> </ul>
Overload or internal sensor supply short-circuit to ground	775 <sub>D</sub>	<p>Possible causes:</p> <ul style="list-style-type: none"> <li>• The internal sensor supply is short-circuited to ground.</li> <li>• Impermissibly high electromagnetic interference is present.</li> </ul>	<ul style="list-style-type: none"> <li>• Eliminate the overload.</li> <li>• Eliminate the short-circuit in the process wiring.</li> <li>• Check the "Sensor supply" parameter.</li> <li>• Eliminate/reduce the electromagnetic interference.</li> </ul>
Channel failure acknowledgment	779 <sub>D</sub>	A channel fault was detected. Confirmation is required to enable the channel.	Confirm the channel fault.
F-address memory not accessible	781 <sub>D</sub>	The F-source address and F-destination address stored in the coding element cannot be accessed.	Verify that the coding element is present or replace the coding element.

Diagnostic alarm	Fault code	Meaning	Remedy
Sensor signal flutters	784 <sub>D</sub>	<p>Too many signal changes have occurred within the time configured with the "Monitoring window" parameter.</p> <ul style="list-style-type: none"> <li>• The "Monitoring window" parameter setting is too high.</li> <li>• The "Number of signal changes" parameter setting is too low.</li> <li>• A momentary interruption/short-circuit of the sensor cable (loose contact) is present.</li> <li>• Impermissibly high electromagnetic interference is present.</li> <li>• The sensor/switch is bouncing.</li> <li>• The sensor is defective.</li> </ul>	<ul style="list-style-type: none"> <li>• Check the "Monitoring window" parameter.</li> <li>• Check the "Number of signal changes" parameter.</li> <li>• Check the process wiring.</li> <li>• Eliminate/reduce the electromagnetic interference.</li> <li>• Replace the sensor.</li> </ul>
Frequency too high	785 <sub>D</sub>	The switching frequency of the encoder is too high.	Reduce the switching frequency of the sensor.
Undertemperature	786 <sub>D</sub>	The minimum permissible temperature limit has been violated.	Operate the F-module within the specified temperature range (see Technical specifications (Page 57))
Input shorted to P	796 <sub>D</sub>	The input signal is short-circuited to L+.	Eliminate the short-circuit.
Supply voltage too high	801 <sub>D</sub>	The supply voltage is too high.	Check the supply voltage.
Supply voltage too low	802 <sub>D</sub>	The supply voltage is too low.	Check the supply voltage.

### Supply voltage outside the nominal range

If the supply voltage L+ is outside the specified value range, the ERROR LED flashes and the module is passivated.

When the voltage is then recovered (level must remain within the specified value for at least 1 minute, see Technical specifications (Page 57)), the ERROR LED stops flashing. The module remains passivated and waits for user acknowledgment.

### Behavior in case of cross circuit/short-circuit to the sensor supply

When internal sensor supply is configured and short-circuit test is deactivated, short-circuits to ground at the sensor supplies are detected. Channels for which the relevant sensor supply is configured will be passivated.

When internal sensor supply is configured and short-circuit test is enabled, short-circuits to ground and potential at the sensor supply are detected. Channels for which the relevant sensor supply is configured will be passivated.

### **Special features for fault detection**

The detection of certain faults (short-circuits or discrepancy errors, for example) depends on the application, the wiring, and the parameter assignment of the short-circuit test and the sensor power supply. For this reason, tables on fault detection for the applications are presented under Applications of the F-I/O module (Page 32).

### **Generally applicable information on diagnostics**

Information on diagnostics that pertains to all F-modules (for example, readout of diagnostics functions or passivation of channels) is available in the SIMATIC Safety – Configuring and Programming (<http://support.automation.siemens.com/WW/view/en/54110126>) manual.



# Technical specifications

## Technical specifications of F-DI 16x24VDC

	6ES7526-1BH00-0AB0
<b>General information</b>	
Product type designation	F-DI 16x24VDC
Firmware version	
<ul style="list-style-type: none"> <li>FW update possible</li> </ul>	Yes
<b>Product function</b>	
I&M data	Yes; I&M0 to I&M3
<b>Engineering with</b>	
STEP 7 TIA Portal can be configured/integrated as of version	V13 SP1 with HSP0086
<b>Operating mode</b>	
DI	Yes
<b>Supply voltage</b>	
Rated value (DC)	24 V
Low limit of permitted range (DC)	19.2 V
High limit of permitted range (DC)	28.8 V
Reverse polarity protection	Yes
<b>Input current</b>	
Current consumption (rated value)	50 mA
<b>Sensor supply</b>	
Number of outputs	4
Short-circuit protection	Yes; electronic (response threshold 0.7 A to 1.8 A)
<b>24 V sensor supply</b>	
24 V	Yes; min. L+ (-1.5 V)
Short-circuit protection	Yes
Output current, max.	300 mA; max. 100 mA with vertical mounting position
<b>Power</b>	
Power consumption from the backplane bus	0.9 W
<b>Power loss</b>	
Power loss, typ.	4.6 W
<b>Address range</b>	
<b>Address space per module</b>	
Address space per module, max.	9 bytes

	6ES7526-1BH00-0AB0
<b>Digital inputs</b>	
Number of inputs	16
m/p-reading	Yes; p-reading
Input characteristic curve according to IEC 61131, Type 1	Yes
<b>Input voltage</b>	
Rated value (DC)	24 V
For "0" signal	-30 ... +5 V
For "1" signal	+15 ... +30 V
<b>Input current</b>	
For "1" signal, typ.	3.7 mA
<b>Input delay (for rated value of input voltage)</b>	
For standard inputs	
<ul style="list-style-type: none"> <li>• Configurable</li> <li>• For "0" to "1", min.</li> <li>• For "0" to "1", max.</li> <li>• For "1" to "0", min.</li> <li>• For "1" to "0", max.</li> </ul>	Yes 0.4 ms 20 ms 0.4 ms 20 ms
<b>Cable length</b>	
shielded, max.	1000 m
unshielded, max.	500 m
<b>Interrupts/diagnostics/status information</b>	
<b>Interrupts</b>	
Diagnostic interrupt	Yes
Hardware interrupt	No
<b>Diagnostic alarms</b>	
Diagnostics	Yes
Monitoring of supply voltage	Yes
Wire break	No
Short-circuit	Yes
Group error	Yes
<b>Diagnostics display LED</b>	
RUN LED	Yes; green LED
ERROR LED	Yes; red LED
Channel status display	Yes; green LED
For channel diagnostics	Yes; red LED
For module diagnostics	Yes; red LED
<b>Electrical isolation</b>	
<b>Electrical isolation, channels</b>	
Between channels and backplane bus	Yes
<b>Permitted potential difference</b>	
Between different circuits	75 V DC/60 V AC (basic insulation)

<b>6ES7526-1BH00-0AB0</b>	
<b>Insulation</b>	
Insulation test voltage	707 VDC (type test)
<b>Standards, approvals, certificates</b>	
<b>Maximum achievable safety class in safety mode</b>	
Performance level according to EN ISO 13849-1:2008	PLe
SIL according to IEC 61508	SIL 3
Low demand mode: PFDavg according to SIL3	< 5.00E-05
High demand/continuous mode: PFH according to SIL3	< 1.00E-09 1/h
<b>Environmental conditions</b>	
<b>Ambient temperature in operation</b>	
Horizontal installation, min.	0 °C
Horizontal installation, max.	60 °C
Vertical installation, min.	0 °C
Vertical installation, max.	40 °C
<b>Dimensions</b>	
Width	35 mm
Height	147 mm
Depth	129 mm
<b>Weights</b>	
Weight, approx.	280 g

## Dimension drawing

See system manual S7-1500 Automation System  
<http://support.automation.siemens.com/WW/view/en/59191792>).

# Response times

## Introduction

The next section shows the response times of the digital input module F-DI 16x24VDC. The response times of the digital input module F-DI 16x24VDC are included in the calculation of the F-system response time.

## Definition of cycle time for fail-safe digital inputs

The cycle time indicates the time between the occurrence of an event and the transfer to the backplane bus.

## Times required for the calculation

- Max. cycle time:  $T_{\text{cycle}} = 5 \text{ ms}$
- Max. acknowledgment time (Device Acknowledgment Time):  $T_{\text{DAT}} = 10 \text{ ms}$

The maximum response time in the case of fault (One Fault Delay Time, OFDT) is equivalent to the maximum response time with no faults (Worst Case Delay Time, WCDDT).

## Maximum response time with no faults (Worst Case Delay Time, WCDDT) during 1oo1 evaluation

The following formula applies to a sensor supply without short-circuit test:

$$t \leq 2 * \text{cycle time} + \text{input delay}$$

The following formula applies to a sensor supply with short-circuit test:

$$t \leq 2 * \text{cycle time} + \text{input delay} + T1 + T2$$

T1 Time for short-circuit test

T2 Startup time of sensors after the short-circuit test

## Maximum response time with no faults (Worst Case Delay Time, WCDDT) during 1oo2 evaluation

The following formula applies to a sensor supply without short-circuit test:

$$t \leq 2 * \text{cycle time} + \text{input delay} + \text{discrepancy time}^*$$

\* Obsolete with discrepancy behavior "Supply value 0"

The following formula applies to a sensor supply with short-circuit test:

$$t \leq 2 * \text{cycle time} + \text{input delay} + \max(T1p + T2p, T1s + T2s) + \text{discrepancy time}^*$$

\* Obsolete with discrepancy behavior "Supply value 0"

T1p Test time for the sensor supply of sensor 1

T2p Startup time of sensor after the short-circuit test (sensor 1)

T1s Test time for the sensor supply of sensor 2

T2s Startup time of sensor after the short-circuit test (sensor 2)

**Maximum response time to external short-circuits**

$$t \leq \max (120 \text{ ms}, 2 * (n \times \text{cycle time}) + \sum [x=0\dots3](T1x + T2x)) + \text{cycle time}$$

T1x	Time for the sensor test
T2x	Startup time of sensors after the short-circuit test
n	Number of sensor supplies with activated short-circuit test
x	Sensor supply

**Maximum response time to discrepancy errors during 1oo2 evaluation**

$$t \leq 2 * \text{cycle time} + \text{input delay} + \text{discrepancy time} + 2 * \max (T1p + T2p, T1s + T2s)$$

n	Number of sensor supplies with activated short-circuit test
T1x	Time for the sensor test
T2x	Startup time of sensors after the short-circuit test
T1p	Test time for the sensor supply of sensor 1
T2p	Startup time of sensor after the short-circuit test (sensor 1)
T1s	Test time for the sensor supply of sensor 2
T2s	Startup time of sensor after the short-circuit test (sensor 2)
x	Sensor supply

# Open Source Software

For Resellers: In order to avoid infringements of the license conditions by the reseller or the buyer these instructions and license conditions and accompanying CD – if applicable - have to be forwarded to the buyers.

## 1) Siemens License Conditions

### General License Conditions for Software Products for Automation and Drives

(2011-08-01)

#### 1. Supply of Software to Licensee and Granting of Rights to use the Software

1.1 These General License Conditions shall exclusively apply to the delivery of Software for Automation and Drives to the Licensee. General terms and conditions of the Licensee shall apply only where expressly accepted in writing by us. The scope of delivery of the Software shall be determined by the congruent mutual written declarations of both parties. We shall grant the Licensee rights to use the software specified in the Confirmation of Order or, if the Licensee does not receive a Confirmation of Order, the software specified in the Certificate of License or that specified in the Software Product Sheet, if the Licensee is instead submitted a Software Product Sheet (hereinafter referred to as "SW"). The Certificate of License and the Software Product Sheet shall be collectively referred to as "CoL" hereinafter. The Licensee shall be submitted the CoL when the SW is supplied or in conjunction with the delivery bill. The way in which the SW is supplied is also derived directly from the Confirmation of Order or from the SW purchase order number contained in the Confirmation of Order, in conjunction with the associated order data of our catalog valid at the time of the Confirmation of Order (hereinafter collectively referred to as "Order Data"), or from the CoL. If the Licensee does not receive a data medium, it shall be authorized to copy the SW already available to it to the extent necessary to exercise the rights to use the SW granted to it. The aforesaid shall apply, mutatis mutandis, to electronic supply of the software (downloading). Where reference is made to the Order Data or the CoL in these General License Conditions, the reference to the CoL is of significance if the Licensee has not received a Confirmation of Order. In any case, the data contained in the Order Data is also contained in the CoL.

1.2 The Documentation relating to the SW (hereinafter referred to as "Documentation") shall be purchased separately, unless either the Order Data or CoL contains a stipulation stating that it belongs to the scope of delivery. If the Licensee is authorized to copy the SW in accordance with Clause 1.1, this shall also apply to the Documentation provided that it is included in the scope of delivery.

1.3 In the event that we submit a License Key to the Licensee, which unlocks the SW (hereinafter referred to as "License Key"), this License Key must also be installed.

1.4 The rights granted to the Licensee with respect to the SW are based on the License Type (see Section 2) and the Software Type (see Section 3). The license and Software Types are detailed in the Order Data or CoL. If the SW is supplied electronically or if copying rights are granted for it, the rights and duties specified in these General License Conditions shall apply to the legitimately generated copies.

1.5 If the Licensee is legitimately in possession of a previous SW version/release (hereinafter referred to as "Previous Version"), the Licensee shall be authorized to exercise the rights to use the SW granted to it either with respect to the SW or - if this is intended from a technical point of view - to the Previous Version, at its own discretion (downgrading). If the SW is an Upgrade or PowerPack in accordance with Section 4, Section 4 shall apply additionally.

1.6 If Previous Versions are listed in the Readme file of the SW under the category "parallel use", the Licensee has the right to exercise, alternatively to the user rights granted to him for the SW, the user rights for the listed Previous Versions in one (1) Instance. If the "Type of use" named in the Order Data or the CoL is: "Installation" or "User", the Licensee is entitled to the previously described right additionally to and at the same time as the Previous Versions listed in one Instance. An "Instance" in the context of these General License Conditions is either an instance in a physical operating system environment or an instance in a virtual operating system environment. The transferability of the user rights onto Previous Versions is only permissible in conjunction with the user rights for the SW in accordance with Clause 5.3.

1.7 In case the Licensee obtains only the data media but no license as per the Order Data or the CoL, any use of the SW by the Licensee is subject to the acquisition of a license according to Section 2. Up to the acquisition of the license, the Licensee is not entitled to supply the SW to third parties.

1.8 In case the SW contains Open Source Software or any similar software of a third party (hereinafter referred to as "OSS") the OSS is listed in the Readme\_OSS-file of the SW. The Licensee is entitled to use the OSS in accordance with the respective license conditions of the OSS. The license conditions are provided on the same data carrier as the SW. The license conditions of the respective OSS shall prevail over these General License Conditions with respect to the OSS. If the license conditions of the OSS require the distribution of the source code of such OSS we shall provide such source code on request against payment of the shipping and handling charges.

1.9 The SW may be or contain licensed software other than OSS, i.e. software which has not been developed by us itself but which has been licensed to us by a third party (hereinafter referred to as the "Licensor"), e.g. Microsoft Licensing Inc. If the Licensee receives the terms and conditions stipulated by the relevant Licensor together with the SW in the Readme\_OSS file in this case, such terms and conditions shall apply with respect to the Licensor's liability vis-à-vis the Licensee. Our own liability vis-à-vis the Licensee shall be governed in any case by these General License Conditions.

#### 2. License Type

Depending on the License Type, the Licensee shall be granted the following rights to the SW:

##### 2.1 Single License (One Off License, Copy License)

The term "One Off License" or "Copy License" which may be used in the Software Product Sheet corresponds to the term "Single License". The following regulation shall apply to the full scope of the One Off License / Copy License. The Licensee shall be granted the non-exclusive right, transferable in accordance with Clause 5.3 and valid for an unlimited period of time, to install the SW in one (1) Instance and to utilize the SW thus installed in the manner specified in the Order Data or CoL (see "Type of Use").

##### 2.2 Floating License

The Licensee shall be granted the non-exclusive right, transferable in accordance with Clause 5.3 and valid for an unlimited period of time, to install the SW on any desired number of the Licensee's hardware devices. The number of objects (for example, users or devices) permitted to utilize the SW at the same time can be derived from the Order Data or CoL (see "Type of Use").

##### 2.3 Rental License

The Licensee shall be granted the non-exclusive right, transferable in accordance with Clause 5.3 and limited in time as stipulated in the Order Data or CoL (see "Type of Use"), to install and use the SW in one (1) Instance. If the period of use is specified in hours, the usage decisive for the calculation of the time limit commences with the software start-up and finishes with its shut-down. If the period of usage is specified in days, weeks or months, the specified period, which commences in conjunction with the first SW start-up, shall apply independently of the actual time of usage. If the period of use is specified with a date, the right of use ends on this date – regardless of the actual period of use.

##### 2.4 Rental Floating License

The Licensee shall be granted the non-exclusive right, transferable in accordance with Clause 5.3 and limited in time as stipulated in the Order Data or the CoL (s. "Type of Use"), to install the SW on any desired number of the Licensee's hardware devices. The number of objects (for example, users or devices) permitted to utilize the SW at the same time can be derived from the Order Data or CoL (see "Type of Use") as well. If the period of use is specified in hours, the usage decisive for the calculation of the time limit commences with the software start-up and finishes with its shut-down. If the period of usage is specified in days, weeks or months, the specified period, which commences in conjunction with the first SW start-up, shall apply independently of the actual time of usage. If the period of use is specified with a date, the right of use ends on this date – regardless of the actual period of use.

##### 2.5 Demo License

The Licensee shall be granted the non-exclusive right, transferable in accordance with Clause 5.3 and limited in time as stipulated in the Order Data or the CoL (s. "Type of use"), to install the SW in one (1) Instance and to use it for validation purposes. If the period of usage is specified in days, weeks or months, the specified period, which commences in conjunction with the first SW start-up, shall apply independently of the actual time of usage. If the period of use is specified with a date, the right of use ends on this date – regardless of the actual period of use.



## 2.6 Demo Floating License

The Licensee shall be granted the non-exclusive right, transferable in accordance with Clause 5.3 and limited in time as stipulated in the Order Data or the CoL (s. "Type of use"), to install the SW on any desired number of the Licensee's hardware devices. The number of objects (for example, users or devices) permitted to utilize the SW at the same time can be derived from the Order Data or CoL (see "Type of Use") as well. If the period of usage is specified in days, weeks or months, the specified period, which commences in conjunction with the first SW start-up, shall apply independently of the actual time of usage. If the period of use is specified with a date, the right of use ends on this date – regardless of the actual period of use.

## 2.7 Trial License

The Licensee shall be granted the non-exclusive and non-transferable right to install the SW in one (1) Instance and to use it for validation purposes in the manner specified in the Order Data or CoL (see "Type of Use"). The period of usage is limited to 14 days and commences with the SW start-up, unless a different period of usage is specified in the Order Data or CoL.

## 3. Software Type

If the Software Type is not specified in the Order Data or CoL, the rights specified in Clause 3.2 (Runtime Software) shall apply to the SW.

### 3.1 Engineering Software (hereinafter referred to as "E-SW")

In the event that the Licensee uses E-SW to generate its own programs or data containing parts of the E-SW, the Licensee shall have the right, without having to pay any license fee, to copy and to use these parts of the E-SW as a part of its own programs or data, or to supply them to third parties for use. In the event that such parts are supplied to third parties for use, these parties shall be bound in writing to comply with stipulations corresponding to those in Clauses 5.1 and 5.2 with respect to the above parts of the E-SW.

### 3.2 Runtime Software (hereinafter referred to as "R-SW")

If the Licensee incorporates R-SW or any parts thereof into its own programs or data, it shall purchase a license with respect to the R-SW each time it installs or copies - depending on what is done first - its own programs or data containing R-SW or parts thereof, in accordance with the relevant intended Type of Use and on the basis of the Siemens catalog valid at that time. In the event that the Licensee supplies the specified programs or data to third parties for their use, these parties shall be bound in writing to adhere to stipulations corresponding to those in Section 5, with respect to the R-SW parts contained therein. The aforesaid shall not affect the Licensee's obligation to purchase a license for the R-SW if the R-SW original is copied. If the R-SW contains tools for parameterization/configuration and extended rights have been granted in this regard, this will be detailed in the readme file of the R-SW.

### 4. Upgrade and PowerPack

If it is apparent from the Order Data or CoL, e.g. by the addition "Upgrade" or "PowerPack" after the SW product name, that the SW is an upgrade for another software item (hereinafter referred to as "Source License"), the rights originally granted to the Licensee to use the Source License end in conjunction with the upgrade measure. The rights of use in accordance with Clause 1.6 remain unaffected by this. However, the Licensee is entitled to undo the upgrading (downgrading) - if this is intended from a technical point of view - and to exercise the rights to use the SW granted to it with respect to the Source Version in accordance with Clause 1.5.

## 5. Further Rights and Duties of the Licensee

5.1 Unless a stipulation to the contrary relating to a specific number of copies is contained on the data medium or in the readme file of the SW, the Licensee may generate an appropriate number of copies of every item of SW which it is authorized to use in accordance with these General License Conditions, where such copies shall be used exclusively for data backup purposes. Furthermore the Licensee may only copy the SW if and insofar as it has been granted copying rights by us in writing.

5.2 The Licensee shall not be entitled to modify, decompile or reverse engineer the SW. Nor may it extract any individual parts unless this is permitted by mandatory copyright law. Furthermore, the Licensee shall not be entitled to remove any alphanumeric identifiers, trademarks or copyright notices from the SW or the data medium and, insofar as it is entitled to make copies of the SW, shall copy them without alteration. The aforementioned regulation shall apply accordingly to the Documentation supplied in accordance with Section 1.

5.3 The Licensee shall be entitled to completely transfer the right to use the SW granted to it to a third party, provided that it concludes a written agreement with the third party in conformance with all of the conditions contained in this Section 5 and

on the proviso that it does not retain any copies of the SW. If the Licensee has received a License Key for the SW, this key shall be supplied to the third party together with the SW. Furthermore, the third party shall be submitted the CoL together with these General License Conditions. The Licensee shall submit the CoL received for the SW to us at any time, if requested.

5.4 If the SW is a PowerPack or an Upgrade, the Licensee shall keep the CoL of the Source License and submit it to us at any time, if requested, together with the CoL for the SW. In the event that the Licensee transfers its right to use the PowerPack SW or Upgrade SW in accordance with Clause 5.3, it shall also submit the CoL of the Source License to the third party.

5.5 If the Licensee receives a data medium which, in addition to the SW, contains further software products which are released for use, then it shall have the right to use these released software products exclusively for validation purposes, for a limited period of time and free of charge. The period of use shall be limited to 14 days, commencing with the first start-up of the relevant software program unless a different period is specified e.g. in the readme file of the relevant software product. These software products supplied exclusively for validation purposes shall be governed, mutatis mutandis, by the stipulations contained in these General License Conditions. The Licensee shall not be authorized to pass on these software products separately, i.e. without the SW, to a third party.

The conditions of the purchase contract apply if not otherwise stipulated hereafter for the Open Source Software.

## 2) License Conditions and Disclaimers for Open Source Software and other Licensed Software

In the product "S7-1500 F-SM - V1.0", Copyright Siemens AG, 2015 (hereinafter "Product"), the following Open Source Software is used either unchanged or in a form that we have modified, and additionally the other License Software noted below:

### Liability for Open Source Software

Open Source Software is provided free of charge. We are liable for the Product including Open Source Software contained in accordance with the license conditions applicable to the Product. Any liability for use of Open Source Software beyond the program flow intended for the Product is explicitly excluded. Furthermore, any liability for defects resulting from modifications to the Open Source Software by you or third parties is excluded.

We do not provide any technical support for the Product if it has been modified.

Please note the following license conditions and copyright notices applicable to Open Source Software and other License Software:

Component	Open Source Software [Yes/No]	Acknowledgements	Copyright Information / File
Dinkumware C/C++ Library - 5.01	NO		LICENSE AND COPYRIGHT INFORMATION FOR COMPONENT DINKUMWARE C/C++ LIBRARY - 5.01
GNU GCC libgcc - 4.3.2	YES		LICENSE AND COPYRIGHT INFORMATION FOR COMPONENT GNU GCC LIBGCC - 4.3.2
GNU GCC libstdc++ / libsupc++ - 4.3.2	YES		LICENSE AND COPYRIGHT INFORMATION FOR COMPONENT GNU GCC LIBSTDC++ / LIBSUPC++ - 4.3.2



## LICENSE CONDITIONS AND COPYRIGHT NOTICES

Commercial Software: Dinkumware C/C++ Library - 5.01  
Enclosed you'll find the license conditions and copyright notices applicable for Commercial Software Dinkumware C/C++ Library - 5.01

## License conditions:

© Copyright William E. Kempf 2001  
Permission to use, copy, modify, distribute and sell this software and its documentation for any purpose is hereby granted without fee, provided that the above copyright notice appear in all copies and that both that copyright notice and this permission notice appear in supporting documentation. William E. Kempf makes no representations about the suitability of this software for any purpose. It is provided "as is" without express or implied warranty.

Copyright © 1994  
Hewlett-Packard Company  
Permission to use, copy, modify, distribute and sell this software and its documentation for any purpose is hereby granted without fee, provided that the above copyright notice appear in all copies and that both that copyright notice and this permission notice appear in supporting documentation. Hewlett-Packard Company makes no representations about the suitability of this software for any purpose. It is provided "as is" without express or implied warranty.

## Copyrights:

Copyright 1992 - 2006 by p.j. plauger and jim brodie. all rights reserved.  
Copyright 1992-2006 by p.j. plauger. all rights reserved.ip  
Copyright 1992-2006 by p.j. plauger. portions derived from work copyright 1994 by hewlettpackard company. all rights reserved  
Copyright 1992-2006 by dinkumware, ltd. all rights reserved  
Copyright 1992-2006 by dinkumware, ltd. portions derived from work copyright 2001 by william e. kempf. all rights reserved  
Copyright 1994 hewlettpackard company  
Copyright 1994 by hewlettpackard company  
Copyright william e. kempf 2001  
Copyright 1989-2006 by p.j. plauger. all rights reserved  
Copyright (c) by p.j. plauger. all rights reserved.  
Copyright (c) by dinkumware, ltd. all rights reserved.  
Copyright (c) unicode, inc. all rights reserved.  
(c) Copyright william e. kempf 2001  
Copyright (c) hewlettpackard company  
Copyright (c) by p.j. plauger. all rights reserved.  
Copyright 2006 by dinkumware, ltd.  
Copyright (c) by p.j. plauger, licensed by dinkumware, ltd. all rights reserved.  
the dinkum cec++ library reference is copyright (c) by p.j. plauger. this code is protected by copyright. all rights reserved.  
the dinkum cc++ library reference is copyright (c) by p.j. plauger. this code is protected by copyright. all rights reserved.  
dinkum compleat library, vc++ package (vc++ compilers only) the dinkum compleat library and the dinkum compleat library reference are copyright (c) by p.j. plauger. all rights reserved.

## LICENSE CONDITIONS AND COPYRIGHT NOTICES

Open Source Software: GNU GCC libgcc 4.3.2  
Enclosed you'll find the license conditions and copyright notices applicable for Open Source Software GNU GCC libgcc 4.3.2

## License conditions:

This configure script is free software; the Free Software Foundation gives unlimited permission to copy, distribute and modify it.

This config.status script is free software; the Free Software Foundation gives unlimited permission to copy, distribute and modify it.

## Copyrights:

Copyright (C) 2003 Free Software Foundation, Inc.  
Copyright (C) 2005, 2006 Free Software Foundation  
Copyright (C) 2007 Free Software Foundation, Inc.  
Copyright 1997, 1998, 1999, 2000, 2001, 2002, 2003, 2004, 2005, 2006, 2007, # 2008 Free Software Foundation, Inc.

## LICENSE CONDITIONS AND COPYRIGHT NOTICES

Open Source Software: GNU GCC libstdc++ / libsupc++ 4.3.2  
Enclosed you'll find the license conditions and copyright notices applicable for Open Source Software GNU GCC libstdc++ / libsupc++ 4.3.2

## License conditions:

Distributed under the Boost  
Software License, Version 1.0. (See accompanying file  
LICENSE\_1\_0.txt or copy at [http://www.boost.org/LICENSE\\_1\\_0.txt](http://www.boost.org/LICENSE_1_0.txt))

---  
Boost Software License - Version 1.0 - August 17th, 2003

Permission is hereby granted, free of charge, to any person or organization obtaining a copy of the software and accompanying documentation covered by this license (the "Software") to use, reproduce, display, distribute, execute, and transmit the Software, and to prepare derivative works of the Software, and to permit third-parties to whom the Software is furnished to do so, all subject to the following:

The copyright notices in the Software and this entire statement, including the above license grant, this restriction and the following disclaimer, must be included in all copies of the Software, in whole or in part, and all derivative works of the Software, unless such copies or derivative works are solely in the form of machine-executable object code generated by a source language processor.

THE SOFTWARE IS PROVIDED "AS IS", WITHOUT WARRANTY OF ANY KIND, EXPRESS OR IMPLIED, INCLUDING BUT NOT LIMITED TO THE WARRANTIES OF MERCHANTABILITY, FITNESS FOR A PARTICULAR PURPOSE, TITLE AND NON-INFRINGEMENT. IN NO EVENT SHALL THE COPYRIGHT HOLDERS OR ANYONE DISTRIBUTING THE SOFTWARE BE LIABLE FOR ANY DAMAGES OR OTHER LIABILITY, WHETHER IN CONTRACT, TORT OR OTHERWISE, ARISING FROM, OUT OF OR IN CONNECTION WITH THE SOFTWARE OR THE USE OR OTHER DEALINGS IN THE SOFTWARE.

This is free software; see the source for copying conditions. There is NO warranty; not even for MERCHANTABILITY or FITNESS FOR A PARTICULAR PURPOSE.

This file is free software; the Free Software Foundation gives unlimited permission to copy and/or distribute it, with or without modifications, as long as this notice is preserved.

Free Software Foundation, Inc.  
This file is free software; the Free Software Foundation gives unlimited permission to copy and/or distribute it, with or without modifications, as long as this notice is preserved. This program is distributed in the hope that it will be useful, but WITHOUT ANY WARRANTY, to the extent permitted by law; without even the implied warranty of MERCHANTABILITY or FITNESS FOR A PARTICULAR PURPOSE.

Permission to copy, use, modify, sell and distribute this software is granted provided this copyright notice appears in all copies. This software is provided "as is" without express or implied warranty, and with no claim as to its suitability for any purpose.

This Makefile.in is free software; the Free Software Foundation gives unlimited permission to copy and/or distribute it, with or without modifications, as long as this notice is preserved. This program is distributed in the hope that it will be useful, but WITHOUT ANY WARRANTY, to the extent permitted by law; without even the implied warranty of MERCHANTABILITY or FITNESS FOR A PARTICULAR PURPOSE.

This configure script is free software; the Free Software Foundation gives unlimited permission to copy, distribute and modify it.

Permission to use, copy, modify, distribute and sell this software and its documentation for any purpose is hereby granted without fee, provided that the above copyright notice appear in all copies and that both that copyright notice and this permission notice appear in supporting documentation. Silicon Graphics makes no representations about the suitability of this software for any purpose. It is provided "as is" without express or implied warranty.

Permission to use, copy, modify, sell, and distribute this software is hereby granted without fee, provided that the above copyright notice appears in all copies, and that both that copyright notice and this permission notice appear in supporting documentation.

<p>None of the above authors, nor IBM Haifa Research Laboratories, Red Hat, or both, make any representation about the suitability of this software for any purpose. It is provided "as is" without express or implied warranty.

Permission to use, copy, modify, sell, and distribute this software is hereby granted without fee, provided that the above copyright notice appears in all copies, and that both that copyright notice and this permission notice appear in supporting documentation. None of the above authors, nor IBM Haifa Research Laboratories, make any representation about the suitability of this software for any purpose. It is provided "as is" without express or implied warranty.

Permission to use, copy, modify, distribute and sell this software and its documentation for any purpose is hereby granted without fee, provided that the above copyright notice appear in all copies and that both that copyright notice and this permission notice appear in supporting documentation. Hewlett-Packard Company makes no representations about the suitability of this software for any purpose. It is provided "as is" without express or implied warranty.

Verbatim copying and distribution of this entire article are permitted worldwide, without royalty, in any medium, provided this notice is preserved.

<para>Report any problems or suggestions to <email>webmaster@fsf.org</email>.</para></appendix>

Copyrights:

- (C) Copyright Jeremy Siek 2000.
- Copyright &copy; 1994 Hewlett-Packard Company
- Copyright &copy; 1998 by Information Technology Industry Council.
- Copyright &copy; 2007 Free Software Foundation, Inc.
- Copyright (C) Microsoft Corporation 1984-2002. All rights reserved.

Copyright (C) 1994, 1995, 1996, 1997, 1998, 1999, 2000, 2001 // Free Software Foundation

Copyright (C) 1994, 1995, 1996, 1997, 1998, 1999, 2000, 2001, 2002 // Free Software Foundation

Copyright (C) 1994, 1995, 1996, 1997, 1998, 1999, 2000, 2001, 2002, # 2003, 2004, 2005 Free Software Foundation, Inc.

Copyright (C) 1994, 1995, 1996, 1997, 1998, 1999, 2000, 2001, 2002, // 2003, 2004, 2005, 2006, 2007 // Free Software Foundation

Copyright (C) 1994, 1995, 1996, 1997, 1998, 1999, 2000, 2001, 2002, // 2003, 2004, 2005, 2006, 2007 Free Software Foundation, Inc.

Copyright (C) 1994, 1995, 1996, 1998, 1999, 2000, 2001, 2004 // Free Software Foundation

Copyright (C) 1994, 1996, 1997, 1998, 1999, 2000, 2001, 2002 // Free Software Foundation

Copyright (C) 1994, 1996, 1997, 1998, 1999, 2000, 2001, 2002, 2007 // Free Software Foundation

Copyright (C) 1994, 1999, 2000, 2003 Free Software Foundation, Inc.

Copyright (C) 1994, 1999, 2000, 2003, 2005 Free Software Foundation, Inc.

Copyright (C) 1994, 1999, 2001, 2002, 2003 Free Software Foundation, Inc.

Copyright (C) 1994, 1999, 2001, 2003 Free Software Foundation, Inc.

Copyright (C) 1995, 1996, 1997, 1998, 1999, 2000, 2001, 2002, 2003, // 2004, 2005, 2006, 2007 // Free Software Foundation

Copyright (C) 1996, 1997, 1998, 1999, 2000, 2001, 2002, 2003, 2004, # 2005 Free Software Foundation, Inc.

Copyright (C) 1996, 1997, 1998, 1999, 2000, 2001, 2002, 2003, 2004, // 2005, 2006, 2007 // Free Software Foundation

Copyright (C) 1996, 1997, 1998, 1999, 2000, 2001, 2002, 2003, 2004, 2005 # Free Software Foundation, Inc.

Copyright (C) 1996, 1997, 2000, 2001, 2003, 2005 # Free Software Foundation, Inc.

Copyright (C) 1996, 1998, 2000, 2001, 2002, 2003, 2004, 2005 # Free Software Foundation, Inc.

Copyright (C) 1997, 1998, 1999 Free Software Foundation, Inc.

Copyright (C) 1997, 1998, 1999, 2000, 2001, 2002 // Free Software Foundation, Inc.

Copyright (C) 1997, 1998, 1999, 2000, 2001, 2002 // Free Software Foundation, Inc.

Copyright (C) 1997, 1998, 1999, 2000, 2001, 2002 // Free Software Foundation, Inc.

Copyright (C) 1997, 1998, 1999, 2000, 2001, 2002, 2003 ## Free Software Foundation, Inc.

Copyright (C) 1997, 1998, 1999, 2000, 2001, 2002, 2003 // Free Software Foundation, Inc.

Copyright (C) 1997, 1998, 1999, 2000, 2001, 2002, 2003, 2004 // Free Software Foundation, Inc.

Copyright (C) 1997, 1998, 1999, 2000, 2001, 2002, 2003, 2004, // 2005, 2006, 2007 // Free Software Foundation, Inc.

Copyright (C) 1997, 1998, 1999, 2000, 2001, 2002, 2003, 2004, // 2005, 2006, 2007 Free Software Foundation, Inc.

Copyright (C) 1997, 1998, 1999, 2000, 2001, 2002, 2003, 2004, 2005 // 2006, 2007 // Free Software Foundation, Inc.





Copyright (C) 1999, 2000, 2001, 2002, 2003, 2006 // Free Software Foundation, Inc.

Copyright (C) 1999, 2000, 2001, 2002, 2004, 2005 // Free Software Foundation, Inc.

Copyright (C) 1999, 2000, 2001, 2003 Free Software Foundation

Copyright (C) 1999, 2000, 2001, 2003, 2004, 2005 // Free Software Foundation, Inc.

Copyright (C) 1999, 2000, 2001, 2004, 2005 Free Software Foundation, Inc.

Copyright (C) 1999, 2000, 2002, 2003 Free Software Foundation

Copyright (C) 1999, 2000, 2002, 2003 Free Software Foundation, Inc.

Copyright (C) 1999, 2000, 2002, 2003, 2004, 2005 // Free Software Foundation, Inc.

Copyright (C) 1999, 2000, 2002, 2003, 2005 Free Software Foundation

Copyright (C) 1999, 2000, 2003 Free Software Foundation

Copyright (C) 1999, 2000, 2003 Free Software Foundation, Inc.

Copyright (C) 1999, 2001, 2002, 2003, 2004 Free Software Foundation

Copyright (C) 1999, 2001, 2002, 2003, 2004, 2005 // Free Software Foundation, Inc.

Copyright (C) 1999, 2001, 2002, 2003, 2004, 2005 Free Software Foundation

Copyright (C) 1999, 2001, 2002, 2003, 2004, 2005, 2006 // Free Software Foundation, Inc.

Copyright (C) 1999, 2001, 2002, 2005, 2006 Free Software Foundation, Inc.

Copyright (C) 1999, 2001, 2003 Free Software Foundation

Copyright (C) 1999, 2001, 2003 Free Software Foundation, Inc.

Copyright (C) 1999, 2001, 2003, 2004 Free Software Foundation

Copyright (C) 1999, 2001, 2003, 2007 Free Software Foundation, Inc.

Copyright (C) 1999, 2001, 2004, 2005 Free Software Foundation, Inc.

Copyright (C) 1999, 2002 Free Software Foundation, Inc.

Copyright (C) 1999, 2002, 2003 Free Software Foundation, Inc.

Copyright (C) 1999, 2002, 2003, 2004 Free Software Foundation, Inc.

Copyright (C) 1999, 2002, 2003, 2004, 2005 // Free Software Foundation, Inc.

Copyright (C) 1999, 2002, 2003, 2004, 2005 Free Software Foundation, Inc.

Copyright (C) 1999, 2002, 2003, 2005 Free Software Foundation, Inc.

Copyright (C) 1999, 2002, 2003, 2005 Free Software Foundation, Inc.

Copyright (C) 1999, 2002, 2004, 2005 Free Software Foundation, Inc.

Copyright (C) 1999, 2003 Free Software Foundation

Copyright (C) 1999, 2003 Free Software Foundation, Inc.

Copyright (C) 1999, 2003, 2004, 2005 Free Software Foundation, Inc.

Copyright (C) 1999, 2003, 2005 Free Software Foundation

Copyright (C) 1999, 2003, 2005 Free Software Foundation, Inc.

Copyright (C) 1999, 2003, 2005 Free Software Foundation, Inc.

Copyright (C) 1999, 2004, 2005 Free Software Foundation, Inc.

Copyright (C) 1999, 2007 Free Software Foundation, Inc.

Copyright (C) 1999-2001, 2002, 2003 Free Software Foundation, Inc.

Copyright (C) 1999-2001, 2002, 2003, 2004, 2005 // Free Software Foundation, Inc.

Copyright (C) 2000 Free Software Foundation, Inc.

Copyright (C) 2000, 1999 Free Software Foundation, Inc.

Copyright (C) 2000, 2001 Free Software Foundation

Copyright (C) 2000, 2001, 2002 Free Software Foundation,

Copyright (C) 2000, 2001, 2002 Free Software Foundation, <abbrev>Inc.</abbrev> 51 Franklin <abbrev>St</abbrev>, Fifth Floor, Boston, <abbrev>MA</abbrev> 02110-1301

Copyright (C) 2000, 2001, 2002 Free Software Foundation, Inc.

Copyright (C) 2000, 2001, 2002, 2003 Free Software Foundation

Copyright (C) 2000, 2001, 2002, 2003 Free Software Foundation, Inc.

Copyright (C) 2000, 2001, 2002, 2003, 2004 Free Software Foundation

Copyright (C) 2000, 2001, 2002, 2003, 2004, 2005 // Free Software Foundation, Inc.

Copyright (C) 2000, 2001, 2002, 2003, 2004, 2005, 2006 // Free Software Foundation

Copyright (C) 2000, 2001, 2002, 2003, 2004, 2005, 2006 // Free Software Foundation, Inc.

Copyright (C) 2000, 2001, 2002, 2003, 2004, 2005, 2006, 2007 // Free Software Foundation, Inc.

Copyright (C) 2000, 2001, 2002, 2003, 2004, 2005, 2006, 2007 // Free Software Foundation

Copyright (C) 2000, 2001, 2002, 2003, 2004, 2005, 2006, 2007 // Free Software Foundation, Inc.

Copyright (C) 2000, 2001, 2002, 2003, 2004, 2005, 2006, 2007, 2008 // Free Software Foundation, Inc.

Copyright (C) 2000, 2001, 2002, 2003, 2004, 2005, 2007 ## Free Software Foundation, Inc.

Copyright (C) 2000, 2001, 2002, 2003, 2004, 2006, 2007 // Free Software Foundation, Inc.

Copyright (C) 2000, 2001, 2002, 2003, 2005 Free Software Foundation

Copyright (C) 2000, 2001, 2002, 2003, 2005 Free Software Foundation, Inc.

Copyright (C) 2000, 2001, 2002, 2003, 2006 Free Software Foundation, Inc.

Copyright (C) 2000, 2001, 2002, 2003, 2007 Free Software Foundation

Copyright (C) 2000, 2001, 2003 Free Software Foundation, Inc.

Copyright (C) 2000, 2001, 2003, 2004 Free Software Foundation, Inc.

Copyright (C) 2000, 2001, 2003, 2004, 2005 Free Software Foundation, Inc.

Copyright (C) 2000, 2001, 2003, 2004, 2005, 2006 // Free Software Foundation, Inc.

Copyright (C) 2000, 2001, 2003, 2005 Free Software Foundation, Inc.

Copyright (C) 2000, 2001, 2004, 2005 Free Software Foundation, Inc.

Copyright (C) 2000, 2001, 2005, 2006 Free Software Foundation, Inc.

Copyright (C) 2000, 2002 Free Software Foundation, Inc.

Copyright (C) 2000, 2002, 2003 Free Software Foundation

Copyright (C) 2000, 2002, 2003 Free Software Foundation, Inc.

Copyright (C) 2000, 2002, 2003, 2004 Free Software Foundation

Copyright (C) 2000, 2002, 2003, 2004, 2006, 2007 Free Software Foundation, Inc.

Copyright (C) 2000, 2002, 2003, 2005 Free Software Foundation

Copyright (C) 2000, 2002, 2004, 2005 Free Software Foundation, Inc.

Copyright (C) 2000, 2002, 2005 Free Software Foundation, Inc.

Copyright (C) 2000, 2002, 2005, 2008 Free Software Foundation, Inc.

Copyright (C) 2000, 2002, 2006 Free Software Foundation, Inc.

Copyright (C) 2000, 2003 Free Software Foundation

Copyright (C) 2000, 2003 Free Software Foundation, Inc.

Copyright (C) 2000, 2003, 2004 Free Software Foundation

Copyright (C) 2000, 2003, 2004 Free Software Foundation, Inc.

Copyright (C) 2000, 2003, 2004, 2005 Free Software Foundation, Inc.

Copyright (C) 2000, 2005 Free Software Foundation, Inc.

Copyright (C) 2001 Free Software Foundation

Copyright (C) 2001 Free Software Foundation, Inc.

Copyright (C) 2001 Free Software Foundation, Inc. # Benjamin Kosnik <bkoz@redhat.com>, 2001.

Copyright (C) 2001, 2002 Free Software Foundation, Inc.

Copyright (C) 2001, 2002, 2003 Free Software Foundation

Copyright (C) 2001, 2002, 2003 Free Software Foundation, Inc.

Copyright (C) 2001, 2002, 2003 Peter Dimov

Copyright (C) 2001, 2002, 2003, 2004 Free Software Foundation

Copyright (C) 2001, 2002, 2003, 2004 Free Software Foundation, Inc.

Copyright (C) 2001, 2002, 2003, 2004, 2005 Free Software Foundation

Copyright (C) 2001, 2002, 2003, 2004, 2005 Free Software Foundation, Inc.

Copyright (C) 2001, 2002, 2003, 2004, 2005, 2006 // Free Software Foundation, Inc.

Copyright (C) 2001, 2002, 2003, 2004, 2005, 2006 Free Software Foundation

Copyright (C) 2001, 2002, 2003, 2004, 2005, 2006, 2007 # Free Software Foundation, Inc.

Copyright (C) 2001, 2002, 2003, 2004, 2005, 2006, 2007 // Free Software Foundation

Copyright (C) 2001, 2002, 2003, 2004, 2005, 2006, 2007 // Free Software Foundation, Inc.

Copyright (C) 2001, 2002, 2003, 2004, 2005, 2006, 2007 // Free Software Foundation

Copyright (C) 2001, 2002, 2003, 2004, 2005, 2006, 2007 // Free Software Foundation, Inc.

Copyright (C) 2001, 2002, 2003, 2004, 2005, 2006, 2007, 2008 ## Free Software Foundation, Inc.

Copyright (C) 2001, 2002, 2003, 2004, 2005, 2006, 2007, 2008 // Free Software Foundation

Copyright (C) 2001, 2002, 2003, 2004, 2005, 2006, 2007, 2008 // Free Software Foundation, Inc.

Copyright (C) 2001, 2002, 2003, 2004, 2008 Free Software Foundation, Inc.

Copyright (C) 2001, 2002, 2003, 2005 Free Software Foundation, Inc.

Copyright (C) 2001, 2002, 2003, 2005 Free Software Foundation

Copyright (C) 2001, 2002, 2003, 2005 Free Software Foundation, Inc.

Copyright (C) 2001, 2002, 2003, 2005, 2006 Free Software Foundation

Copyright (C) 2001, 2002, 2003, 2005, 2007 Free Software Foundation, Inc.

Copyright (C) 2001, 2002, 2003, 2006 Free Software Foundation, Inc.

Copyright (C) 2001, 2002, 2003, 2006, 2008 Free Software Foundation, Inc.

Copyright (C) 2001, 2002, 2004 Free Software Foundation, Inc.

Copyright (C) 2001, 2002, 2004, 2005 Free Software Foundation

Copyright (C) 2001, 2002, 2004, 2005 Free Software Foundation, Inc.

Copyright (C) 2001, 2002, 2004, 2005, 2006 Free Software Foundation, Inc.

Copyright (C) 2001, 2002, 2004, 2005, 2007 Free Software Foundation, Inc.

Copyright (C) 2001, 2002, 2004, 2005, 2008 Free Software Foundation, Inc.

Copyright (C) 2001, 2002, 2004, 2006 Free Software Foundation, Inc.

Copyright (C) 2001, 2002, 2005 Free Software Foundation, Inc.

Copyright (C) 2001, 2002, 2005, 2007 Free Software Foundation, Inc.

Copyright (C) 2001, 2002, 2005, 2008 Free Software Foundation, Inc. See license.html for license.

Copyright (C) 2001, 2003 Free Software Foundation

Copyright (C) 2001, 2003 Free Software Foundation

Copyright (C) 2001, 2003 Free Software Foundation, Inc.

Copyright (C) 2001, 2003, 2004 Free Software Foundation, Inc.

Copyright (C) 2001, 2003, 2004, 2005 Free Software Foundation, Inc.

Copyright (C) 2001, 2003, 2005 Free Software Foundation, Inc.

Copyright (C) 2001, 2003, 2005 Free Software Foundation

Copyright (C) 2001, 2003, 2007 Free Software Foundation, Inc.

Copyright (C) 2001, 2004 Free Software Foundation, Inc.

Copyright (C) 2001, 2004, 2005 Free Software Foundation, Inc.

Copyright (C) 2001, 2005 Free Software Foundation, Inc.

Copyright (C) 2001, 2007 Free Software Foundation, Inc.

Copyright (C) 2002 // Free Software Foundation, Inc.

Copyright (C) 2002 Free Software Foundation

Copyright (C) 2002 Free Software Foundation, Inc.

Copyright (C) 2002 Peter Dimov

Copyright (C) 2002, 2003 Free Software Foundation

Copyright (C) 2002, 2003 Free Software Foundation, Inc.

Copyright (C) 2002, 2003, 2004, 2005 Free Software Foundation

Copyright (C) 2002, 2003, 2004, 2005 Free Software Foundation, Inc.

Copyright (C) 2002, 2003, 2004, 2005, 2006, 2007 // Free Software Foundation, Inc.  
Copyright (C) 2002, 2003, 2004, 2005, 2006, 2007, 2008 ## Free Software Foundation, Inc.  
Copyright (C) 2002, 2003, 2004, 2005, 2006, 2007, 2008 Free // Software Foundation  
Copyright (C) 2002, 2003, 2004, 2005, 2007 Free Software Foundation, Inc.  
Copyright (C) 2002, 2003, 2004, 2007 Free Software Foundation, Inc.  
Copyright (C) 2002, 2003, 2005 Free Software Foundation, Inc.  
Copyright (C) 2002, 2003, 2005 Free Software Foundation, Inc.  
Copyright (C) 2002, 2003, 2007 Free Software Foundation, Inc.  
Copyright (C) 2002, 2004 Free Software Foundation  
Copyright (C) 2002, 2004 Free Software Foundation, Inc.  
Copyright (C) 2002, 2004, 2005 Free Software Foundation, Inc.  
Copyright (C) 2002, 2004, 2005, 2007 Free Software Foundation, Inc.  
Copyright (C) 2002, 2004, 2006 Free Software Foundation, Inc.  
Copyright (C) 2002, 2005, 2007 Free Software Foundation, Inc.  
Copyright (C) 2002, 2007 Free Software Foundation, Inc.  
Copyright (C) 2003 // Free Software Foundation, Inc.  
Copyright (C) 2003 Free Software Foundation  
Copyright (C) 2003 Free Software Foundation, Inc.  
Copyright (C) 2003, 2004 // Free Software Foundation, Inc.  
Copyright (C) 2003, 2004 Free Software Foundation  
Copyright (C) 2003, 2004 Free Software Foundation, Inc.  
Copyright (C) 2003, 2004, 2005 // Free Software Foundation, Inc.  
Copyright (C) 2003, 2004, 2005 Free Software Foundation, Inc.  
Copyright (C) 2003, 2004, 2005 Free Software Foundation  
Copyright (C) 2003, 2004, 2005 Free Software Foundation, Inc.  
Copyright (C) 2003, 2004, 2005, 2006 // Free Software Foundation, Inc.  
Copyright (C) 2003, 2004, 2005, 2006 Free Software Foundation  
Copyright (C) 2003, 2004, 2005, 2006 Free Software Foundation, Inc.  
Copyright (C) 2003, 2004, 2005, 2006, 2007 // Free Software Foundation, Inc.  
Copyright (C) 2003, 2004, 2005, 2006, 2007 Free Software Foundation  
Copyright (C) 2003, 2004, 2005, 2006, 2007 Free Software Foundation, Inc.  
Copyright (C) 2003, 2004, 2005, 2006, 2007, 2008 // Free Software Foundation, Inc.  
Copyright (C) 2003, 2004, 2005, 2006, 2007, 2008 Free Software // Foundation, Inc.  
Copyright (C) 2003, 2004, 2005, 2007 Free Software Foundation  
Copyright (C) 2003, 2004, 2005, 2007 Free Software Foundation, Inc.  
Copyright (C) 2003, 2004, 2006 Free Software Foundation, Inc.  
Copyright (C) 2003, 2005 Free Software Foundation

Copyright (C) 2003, 2005 Free Software Foundation, Inc.  
Copyright (C) 2003, 2005, 2006 // Free Software Foundation, Inc.  
Copyright (C) 2003, 2005, 2006 Free Software Foundation, Inc.  
Copyright (C) 2003, 2006 // Free Software Foundation, Inc.  
Copyright (C) 2003, 2007 Free Software Foundation, Inc.  
Copyright (C) 2004 Ami Tavory and Vladimir Dreizin, IBM-HRL.  
Copyright (C) 2004 Free Software Foundation  
Copyright (C) 2004 Free Software Foundation, Inc.  
Copyright (C) 2004, 2005 Free Software Foundation, Inc.  
Copyright (C) 2004, 2005 Free Software Foundation  
Copyright (C) 2004, 2005 Free Software Foundation, Inc.  
Copyright (C) 2004, 2005, 2006 Free Software Foundation  
Copyright (C) 2004, 2005, 2006 Free Software Foundation, Inc.  
Copyright (C) 2004, 2005, 2006, 2007 Free Software Foundation  
Copyright (C) 2004, 2005, 2006, 2007 Free Software Foundation, Inc.  
Copyright (C) 2004, 2005, 2006, 2007, 2008 // Free Software Foundation, Inc.  
Copyright (C) 2004, 2005, 2006, 2007, 2008 Free Software Foundation, Inc.  
Copyright (C) 2004, 2005, 2007 Free Software Foundation  
Copyright (C) 2004, 2005, 2007 Free Software Foundation, Inc.  
Copyright (C) 2004, 2006 Free Software Foundation, Inc.  
Copyright (C) 2004, 2006, 2008 Free Software Foundation, Inc.  
Copyright (C) 2004, 2007 Free Software Foundation, Inc.  
Copyright (C) 2005 Free Software Foundation, Inc.  
Copyright (C) 2005 Free Software Foundation  
Copyright (C) 2005 Free Software Foundation, Inc.  
Copyright (C) 2005, 2006 // Free Software Foundation, Inc.  
Copyright (C) 2005, 2006 Free Software Foundation, Inc.  
Copyright (C) 2005, 2006, 2007 Free Software Foundation  
Copyright (C) 2005, 2006, 2007 Free Software Foundation, Inc.  
Copyright (C) 2005, 2006, 2007, 2008 Free Software Foundation, Inc.  
Copyright (C) 2005, 2006, 2008 Free Software Foundation, Inc.  
Copyright (C) 2005, 2007 Free Software Foundation, Inc.  
Copyright (C) 2006 // Free Software Foundation, Inc.  
Copyright (C) 2006 Free Software Foundation  
Copyright (C) 2006 Free Software Foundation, Inc.  
Copyright (C) 2006, 2006 Free Software Foundation  
Copyright (C) 2006, 2007 Free Software Foundation  
Copyright (C) 2006, 2007 Free Software Foundation, Inc.

